

Motor Protection Controller

User Manual

Applied to:

WDH-31-531

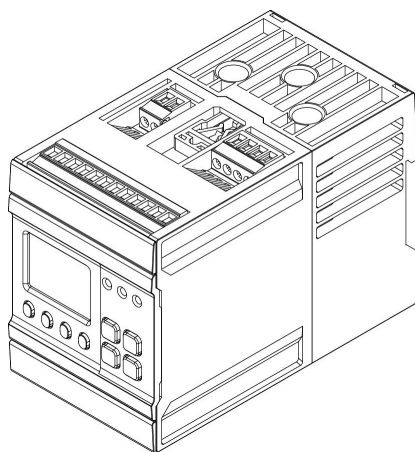

JIANGSU SFERE ELECTRIC CO., LTD.

CONTENT

1 Introduction	1
1.1 Product Overview	1
1.2 Application scenario	3
1.3 Overview of functions	5
1.3.1 Monitoring functions	5
1.3.2 Protection functions	6
1.3.3 Control functions	7
1.3.4 Communication	7
1.3.6 Management functions	9
1.4 Overview of system components	11
1.5 Order codes	13
2. Installation	15
2.1 Size	15
2.1.1 Controller main body installation (5A/25A hole type)	15
2.1.2 Controller main body installation (100A hole type)	15
2.2 Terminal Wiring	17
2.2.1 Diagram of connection between main body and display panel	17
2.2.2 External residual current transformer wiring	18
2.3.3 Voltage input wiring	18
3. Motor protection	19
3.1 Thermal Overload	19
3.2 Stall	21
3.3 Current imbalance	21
3.4 Phase Loss	22
3.5 Under Load	22
3.6 Jam Protection	23
3.7 Short-Circuit	24

3.8 Ground Fault	24
3.9 Residual Current	25
3.10 Start Overtime	26
3.11 Phase sequence	27
3.12 Under Voltage	27
3.13 Over Voltage	28
3.14 Voltage Imbalance	29
3.15 PT Breaking	29
3.16 External Fault	30
3.17 Time t_E (Increased Safety Motor)	31
3.18 Thermistor	32
4. Motor control	33
4.1 Start/stop control logic	33
4.1.1 Command start and stop	33
4.1.2 External bypass start/stop	34
4.2 Control authority	35
4.3 Power on self-starting	36
4.4 Under voltage restart	37
4.4.1 Instant restart	37
4.4.2 Under voltage restart	37
4.5 Analog Output	38
4.6 Start mode	39
4.6.1 Thermal relay	39
4.6.2 Direct start	40
4.6.3 Reversing	41
4.6.4 Two speed start	42
4.6.5 Star Delta start	43
5. Communication	44
5.1 RS485 network	44
5.1.1 Network topology	44

5.1.2 Interface definition	44
5.1.3 Related parameters	44
5.1.4 Modbus instruction sets	45
6. Operation panel	46
6.1 Panel	46
6.2 Control interface	47
6.3 Query interface	48
6.3.1 Running data	49
6.3.2 Alarm	50
6.3.3 Record	50
6.3.4 Maintenance information	51
6.4 Setting interface	52
6.4.1 Basic setup	53
6.4.2 System Setup	53
6.4.3 Start control	54
6.4.4 Protection Setup	55
6.4.5 Self-start Setup	56
6.4.6 Restart Setup	56
6.4.7 Analog output Setup	56
6.4.8 Communication Setup	57
6.4.9 Digital input Setup	57
6.4.10 Digital output Setup	58
6.4.11 System clock	59
7. Fault detail	61
8. Technical data	63
9. Appendix	65
9.1 Overload protection time characteristic table	65
9.2 tE Time Protection Characteristic Table	65

Version number	Date	Description
V1.0	2022.04.22	Initial version
V1.1	2022.06.15	Correct some errors

Precautions

This instruction is intended for use by professionals who are trained and familiar with standards in electrical installation and control and automation engineering.

The responsible person must ensure that the application or use of the product meets all safety requirements.

Abbreviation

DCS	Distributed Control System
PLC	Programmable Logic Controller
NO/NC	Normal Open / Normal close
DI	Digital input
DO	Digital output
AI	Analog input
AO	Analog output
PTC/ NTC	Thermal resistance input
MC	Main module
SCT	Current transformer module

Related document

WDH-31-530 Modbus-RTU protocol manual

1 Introduction

1.1 Product Overview

WDH-31-531 motor protection controller (hereinafter referred to as controller or WDH) is applicable to the application sites of three-phase low-voltage AC motor with rated frequency of 50/60hz, rated voltage of 690V AC and rated current of 800A. The product has the functions of monitoring, control, protection and communication, and provides perfect protection and control for the motor.

Application

- Low voltage three phase AC motor
- Motor independent control box or MCC cabinet
- Reversing and Reduced voltage applications
- Industrial automation, such as belt-transportation, mixing system etc.
- Fire pumps and fans

Advantages

- A variety of protection functions are built in, and the on / off, alarm or trip functions of the protection function are programmable
- Rich starting control, single-step starting (direct / two-way, etc.); Two step starting (star delta / soft start coordination, etc.)
- Under voltage hoisting, power on and self starting function ensure the uninterrupted operation of the motor
- With residual current transformer, additional residual current transformer and external wiring can be avoided
- 1-way PTC / NTC thermistor input for motor temperature monitoring and protection
- 5-way programmable switching value input and 4-way programmable relay output
- 2 Channel Programmable 4 ~ 20mA analog output
- Rich SOE event records, tripping, alarm, start stop, input displacement, etc
- Standard RS485 communication interface, optional Modbus RTU or PROFIBUS DP protocol
- Optional Ethernet communication interface with switch function, Modbus TCP protocol
- Optional black-and-white or color Chinese LCD module to visually display and indicate various parameters, information and status

- Equipped with upper computer management software to realize parameter configuration, debugging and monitoring
- Modular structure design, flexible combination of main body, transformer, display module and optional function
- The installation method is flexible and the overall size is reasonable. It can be installed in 1 / 4 drawer cabinet

1.2 Application scenario

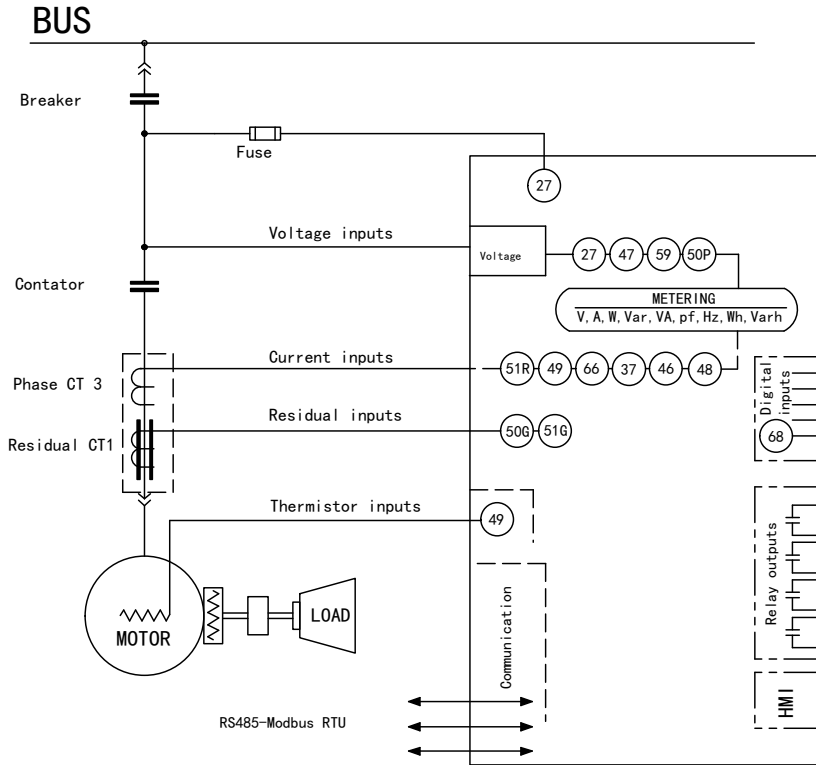

Figure 1 WDH-31-531 Function block diagram

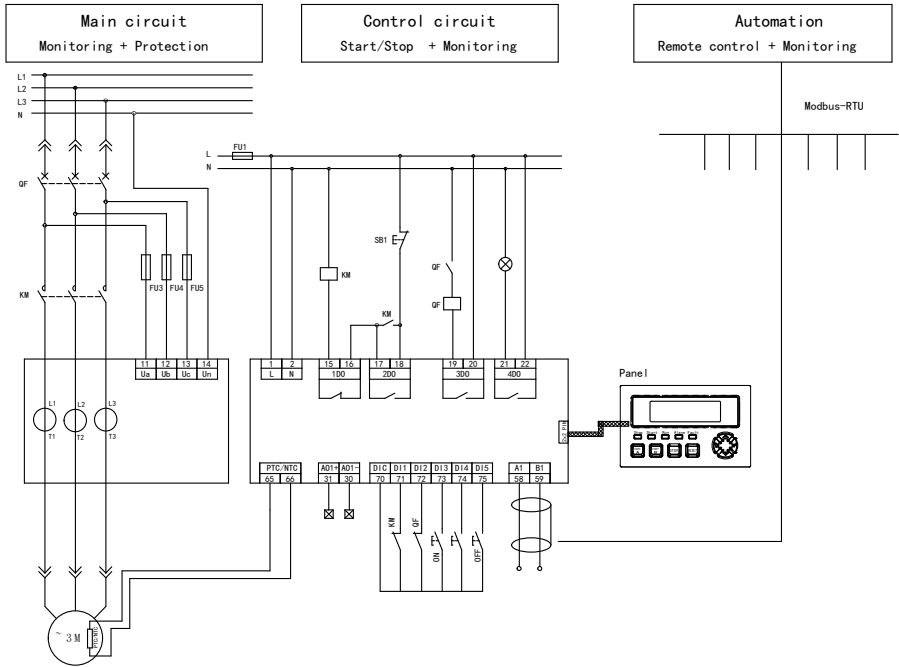

Figure2 WDH-31-531 Typical application diagram

1.3 Overview of functions

1.3.1 Monitoring functions

The controller completes the measurement of important electrical parameters (voltage, current, power, power factor, electric energy, etc.) of the motor circuit through the main module.

- * Direct input line voltage up to 690V
- * Direct input current up to 100A (hole type)
- * Full wave or fundamental wave measurement mode can be selected
- * Residual current can be measured
- * Optional measurement of 1-way thermistor

Measuring parameter		Range	Accuracy/Defenition
Voltage	Voltage RMS (U)	5% ~ 120%Ue	1.0% / 0.1V
	Imbalance (imb U)	0% ~ 100%	--- / 0.1%
	Frequency (F)	45 ~ 65Hz	0.5% / 0.01Hz
Current	Current RMS (I)	2% ~ 1000%Ie	1.0% / 0.1A
	Ground current (Ig)	2% ~ 1000%Ie	1.0% / 0.1A
	Residual current (Ir)	2%~ 400%I Δ n	1.0% / 1mA
	Sequence current (I1/I2)	2% ~ 120%Ie	1.0% / 0.1%
	Imbalance (unb I)	0% ~ 100%	--- / 0.1%
	Thermal capacity (Cc)	0% ~ 100%	--- / 1%
Power	Active Power (P)	0% ~ 120%Pe	1.0% / 0.01kW
	Reactive Power (Q)	0% ~ 120%Pe	1.0% / 0.01kvar
	Power Factor (PF)	0 ~ \pm 1	1.0% / 0.001
	Active energy (EP)	---	2.0% / 0.01kWh
	Reactive energy (EQ)	---	---/ 0.01kvarh
Motor temperature	Thermistors (PTC / NTC)	0 ~ 10k Ω	3.0% / 0.01 k Ω

Table 1. WDH-31-531 Measuring parameter

1.3.2 Protection functions

- * support multiple ANSI standard protection functions
- * Each protection could be selected as drop in or drop out respectively
- * Each protection could be configure as alarm/ trip stage respectively
- * The protection object could be setting as the circuit breaker for the large current protection

	Protection	ANSI code
Current	Thermal Overload Under Load (current or power) Stall Jam Current imbalance Phase loss Short Circuit Ground Fault Residual Current Start overtime time tE	49 37 51LR/50S 51R 46 46 50/51 50N/51N 50G/51G 48
Voltage	Under voltage Over voltage Phase sequence Voltage imbalance PT breaking	27/27P 59 47 46 50P
Non-electric	Thermistor External fault	49 68

Table 2.WDH-31-531 Protection overview & ANSI code

1.3.3 Control functions

- * WDH-31-531 by the main control module to achieve the control of the motor stop/start.
- * Main module contains 5 DI, 4 relay output and 2 analog output
- * By simple programming to achieve the logical control as following:

Motor start type
Uncontrolled : ·Overload relay Single step starting: ·Direct start ·Reversing ·Two speed ·Electro valve Double-step starting: ·Star/Delta start
Control authority
·Panel Position ·Local terminal Position ·Remote terminal Position ·Communication control Position
Uninterrupted operation
·Under voltage restart ·On-power self-start

Table 3. WDH-31-531 control functions overview

1.3.4 Communication

RS485	
Protocol	Modbus-RTU
Interface	3-pin terminal
Slave address	1~247
Baud rate	4800bps~9600bps
Data format	N.8.1、O.8.1、E.8.1、N.8.2
Networking capacity	< 32

1.3.5 I/O interface

DI

- Main control module contains 5 DI
- DI dry contact (internal DC24V)
- Each DI function could be customized

DI: Setting descriptions	
Function	Descriptions
Contactor state	Contactor auxiliary contact feedback signal for monitoring
Local Start	Local terminal start signal input
Local Stop	Local terminal stop signal input
Local STA/STP	Local terminal start, stop signal input
Remote Start	Remote terminal start signal input (connected to DCS output signal)
Remote Stop	Remote terminal stop signal input (connected to DCS output signal)
Remote STA/STP	Remote terminal start, stop signal input (connected to DCS output signal)
Emergency Stop	Emergency stop signal input (no control permission limit)
Interlock Stop	Interlocking stop signal input (no control permission limit)
External Fault	External fault signal input, can be connected to non-electrical sensors, relays, etc.
L/R Switch	Local, remote control permission switching signal input, generally connected to the switch

Table 5. WDH-31-531 DI common functions

Relay output

- Main control module contains 4 relay output(1NC/3NO)
- Functions of each relay output could be customized

Relay output: Function customized	
Function	Descriptions
start A	Start control relay A output for single step start
start B	Start control relay B output for double step start
protection trip	Trip relay or stop relay output
Short circuit fault	Large current overflow fault relay output, connected to circuit breaker OFF coil
Self-diagnostic output	Device equipment fault diagnosis relay output
Device ready output	Device ready relay output (no fault + no stop signal + circuit breaker in position)
Running signal output	Motor running status signal output
Total alarm signal	Motor alarm status signal output
Total trip signal	Motor fault status signal output

Table 6. WDH-31-531 Relay common functions

1.3.6 Management functions

The data management of the motor protector is accomplished by the main control module and could be record the relative data by the display module or the communication interface.

Motor running data management
<ul style="list-style-type: none"> ·Current maximum current during a starting process ·Maximum current during historical starting process ·The maximum current of the current running process ·Maximum current during historical operation ·current running time ·Accumulated running time ·Current stop time ·Total stop time ·Start and stop operations ·Contactor ON/OFF times ·The total number of alarms & trips ·The latest modification of parameter information
SOE record
<ul style="list-style-type: none"> ·12 times Trip Record ·12 times Alarm Record ·12 times Start Record ·12 times Stop Record

- 12 times DI Switch Record
- 12 times Reset Record

Table 7. WDH-31-531 Management functions overview

1.4 Overview of system components

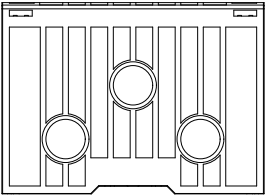
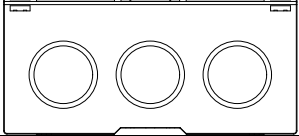
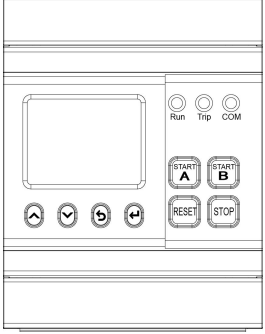
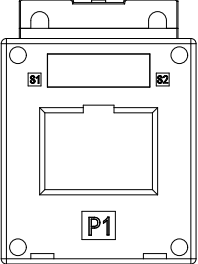
Components	Image	Descriptions
Special protective type current transformer		
Hole type(25A) 5A (0.2A~5A) 25A (2.5A~25A)		<ul style="list-style-type: none"> -Three phase current measurement access -It must be installed integrally with the main body (splicing type) -100A current perforated access
Hole type(100A) 100A (10A~100A)		<ul style="list-style-type: none"> -If the circuit current exceeds 100A, an external primary transformer is required
Main control module		
Main control module (RS485)		<ul style="list-style-type: none"> · din rail mounted (Integrated with the transformer) · Three phase current measurement · Three phase voltage measurement · Residual current measurement · 1 circuit thermistor input · 5-way switching value input · 4-way relay output · 1 channel analog output · 1 channel RS485 communication interface
External CT		
SHI-ZT40 (core size: 40mm)		<ul style="list-style-type: none"> · External CT is inevitable for the current of the main loop is over 100A · SHI-ZT40 (300A:5A) · SHI-ZT40 (500A:5A) · SHI-ZT40 (800A:5A)

SHI-ZT60
(core size: 60mm)

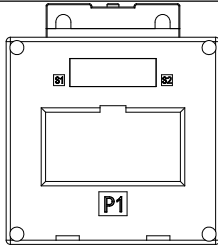

- External CT is inevitable for the current of the main loop is over 100A
- **SHI-ZT60** (300A:5A)
- **SHI-ZT60** (500A:5A)
- **SHI-ZT60** (800A:5A)

1.5 Order codes

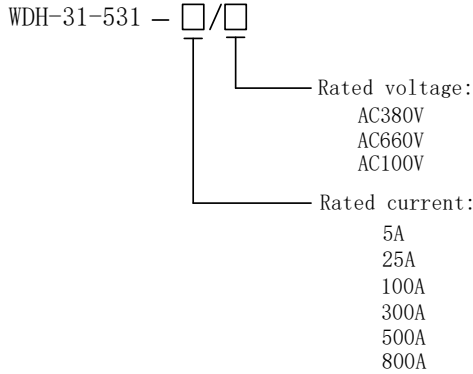

Type selection by rated current			
Code	Range	Motor Power(380VSystem)	Hole size
5A	0.2A~5A	0.13~2kW	Φ10.5mm
25A	5A~25A	2~11kW	Φ10.5mm
100A	25A~100A	11~55kW	Φ18mm
250A	100A~250A	45~115kW(External CT 300A:5A)	Φ10.5mm
500A	200A~500A	90~280kW(External CT 500A:5A)	Φ10.5mm
800A	500A~800A	280~400kW(External CT 800A:5A)	Φ10.5mm

External CT: SHI-ZT40/ZT60	
When the rated current of the motor is over 100A, the current of the measuring module should be at 5A, the external CT is inevitable. The transform ratio should be 500A:5A, 800A:5A etc. The protection accuracy of the CT is 5P10, the measurement accuracy is 0.5 class, 3pcs as 1 set.	
SHI-ZT40 (300A:5A)	Cable diameter Φ40mm
SHI-ZT40 (500A:5A)	Cable diameter Φ40mm
SHI-ZT40 (800A:5A)	Cable diameter Φ40mm
SHI-ZT60 (800A:5A)	Cable diameter Φ60mm
SHI-ZT60 (500A:5A)	Cable diameter Φ60mm

Add-on feature (choose one only)		
Functions	Type	Descriptions
Analog output	M2	2-way analog output function (transmission output)
Temperature input	T	1-way thermistor input (0 ~ 10 k Ω)

Mode Selection Example		
	WDH-31-531 -25A/380V	WDH-31-531 -100A/660V + T
Protocol	1*Modbus	1*Modbus
rated current	25A (5A~25A)	100A (25A~100A)
rated voltage	AC380V	AC660V
DI	DC24V(Passive contact point)	DC24V(Passive contact point)
Additional function	None	1*thermistor input

2. Installation

2.1 Size

2.1.1 Controller main body installation (5A/25A hole type)

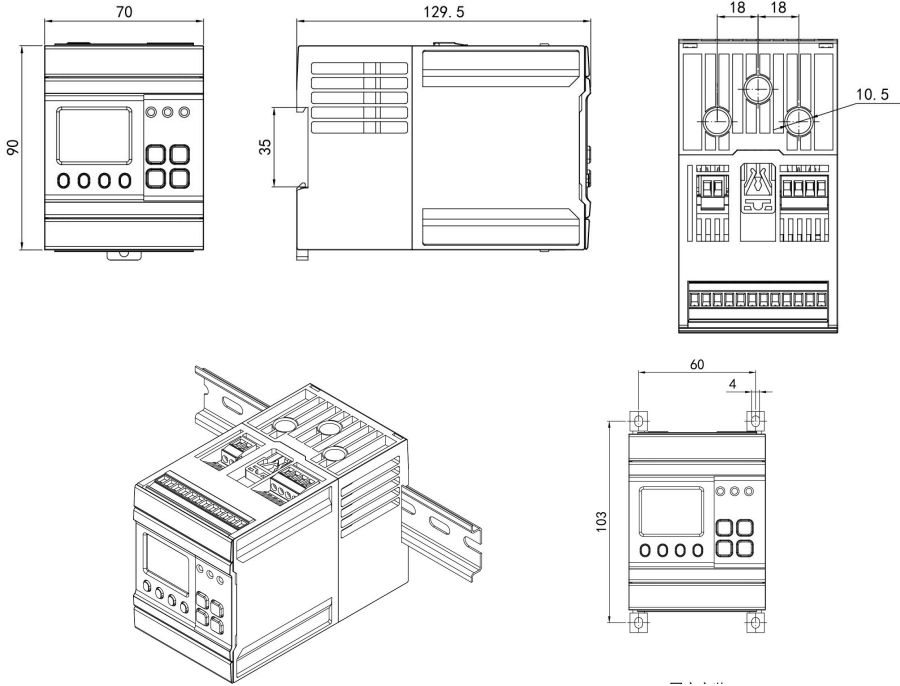

2.1.2 Controller main body installation (100A hole type)

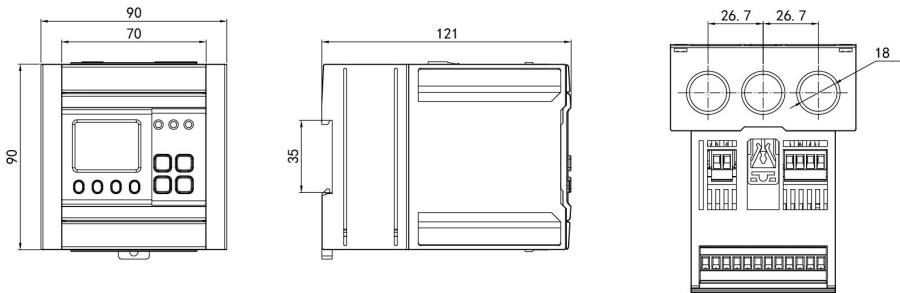

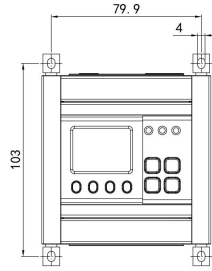
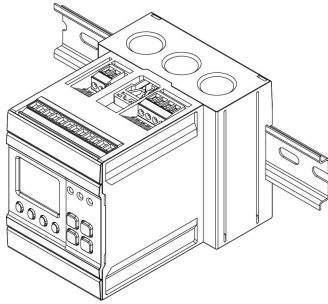

2.1.3 Display panel Module installation

SHI-ZT40 (hole size 40 x 30)

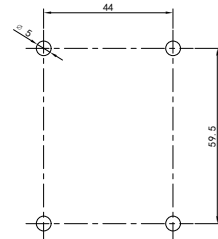
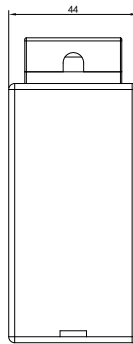
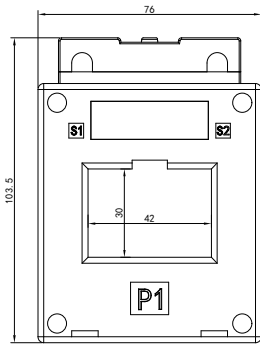

SHI-ZT60 (hole size 60 x 40)

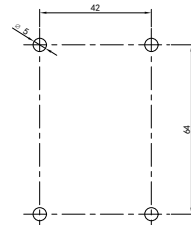
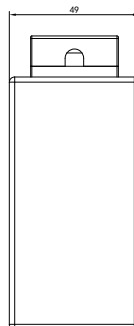
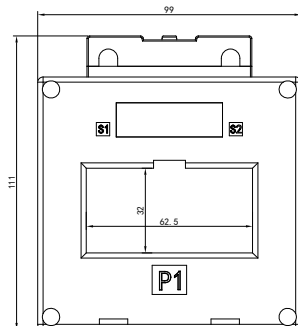

2.2 Terminal Wiring

2.2.1 Diagram of connection between main body and display panel

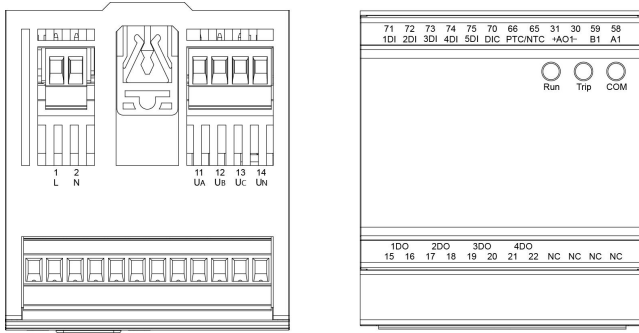

Function	Terminal	Sign	Description
Power supply input	1	L	Power supply input (L / +)
	2	N	Power supply input (N/ -)
Voltage measurement input	11	UA	Phase A voltage input
	12	UB	Phase B voltage input
	13	UC	C phase voltage input
	14	UN	Zero line voltage input
Digital input	70	DIC	The main control module enters the common end
	71	1DI	# 1 Switch quantity input
	72	2DI	# 2 Switch quantity input
	73	3DI	# 3 Switch quantity input
	74	4DI	# 4 Switch quantity input
	75	5DI	# 5 Switch quantity input
Digital output	15	1DO	# 1 Relay output
	16		
	17	2DO	# 2 Relay output
	18		
	19	3DO	# 3 Relay output
	20		
	21	4DO	# 4 Relay output
	22		

Analog output	30	AO1-	Analog output (-)
	31	AO1+	Analog output (+)
PT100 input	65	PTC/NTC	Thermal resistance input
	66		
Communication output	58	A1	#1- RS485-Modbus A
	59	B1	#1- RS485-Modbus B

2.2.2 External residual current transformer wiring

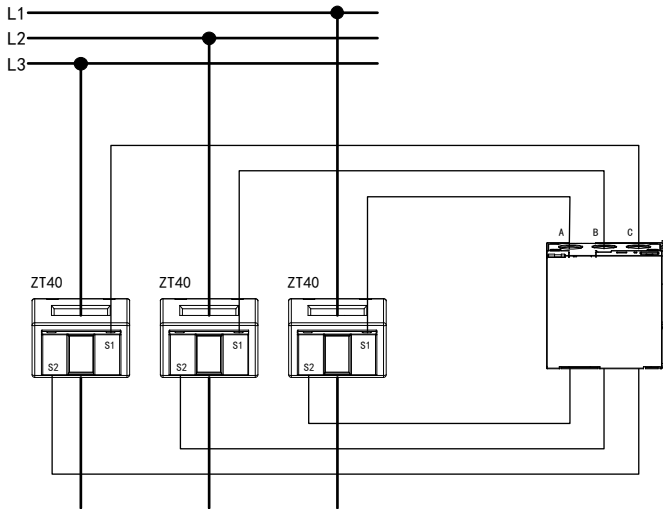

2.3.3 Voltage input wiring

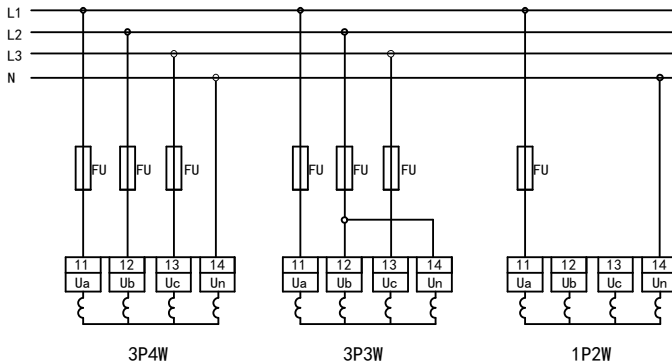

3. Motor protection

3.1 Thermal Overload

The thermal overload protection is monitoring the motor heating status by stimulating the motor heat capacity under star/running circumstance so as to eliminate the motor repetitive start under over heat for ensuring the motor running in normal circumstance.

Thermal overload protection provides 12 inverse-time protection curve (trip class), comforts to IEC 60947-4-1.

Overload curve No	IEC Trip Class	Rectification Times	1.2	1.5	7.2
125	10A	Trip time	≤60min	≤2min	2s<T≤10s
250, 300	10			≤4min	4s<T≤10s
500	20			≤8min	6s<T≤20s
750	30			≤12min	9s<T≤30s

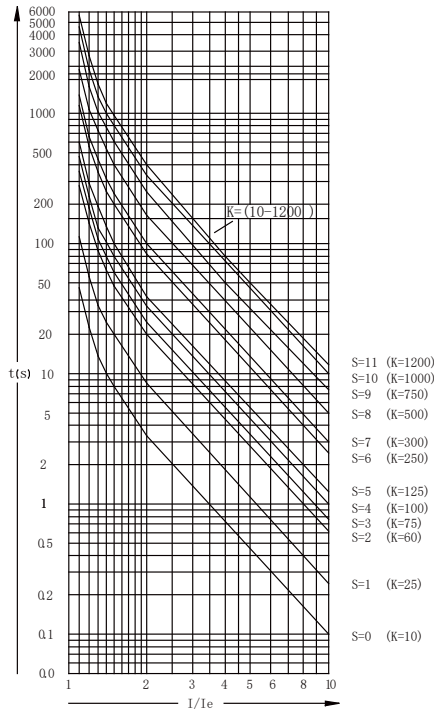

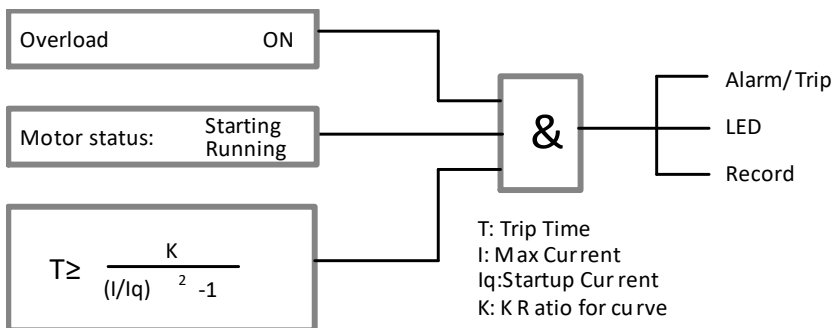

Figure 2.Overload protection logic

Parameters	Range	Defaults
Protection Enable	OFF / Alarm/ Trip / Alarm&Trip	Alarm&Trip
Startup current	90%I _e ~ 200%I _e	100%I _e
Overload curve	10 ~ 1200	125
Alarm level	20% ~ 100%	90%
Cooling time	0 min ~ 120 min	5min
Reset Cc Level	0% ~ 50%	15%
Trip reset mode	Manual / Auto	Manu

Table 8.Overload protection related parameters

Startup current: For the production continuance, the overload running of the motor in a certain range is accepted, therefore enhance the protection startup current to reduce the trip current ratio.

Cooling time: Cooling time should be defined as the require time from the motor overload trip to a stable environmental temperature (maximum tolerance temperature), normally refer to the period which the heat capacity decent from 100% to 15%. The user could set it as 30 minutes for complete chilling. The thermal overload fault could not be reset unless the cooling time is up.

Trip reset mode: After thermal overload tripping, the heat capacity decent to the resettable level or below, as for the cooling time is up, the reset type chose "Auto" than the fault status will be reset, on the contrary, the reset type chose "Manual" than the fault status could not be clear automatically, it has to reset by manual.

3.2 Stall

Stall protection is the time-limited current protection during start-up, and automatically exits after the start.

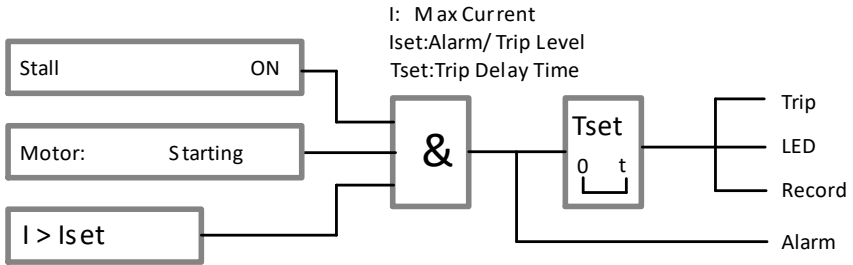

Figure 3. Jam protection logic

Parameter	Range	Default
Protection enable	OFF / Alarm / Trip / Alarm&Trip	OFF
Alarm level	100%Ie ~ 1000%Ie	300%Ie
Trip level	100%Ie ~ 1000%Ie	400%Ie
Trip-delay starting	0.1s ~ 600.0s	3.0s

Table 9. Stall protection related parameters

3.3 Current imbalance

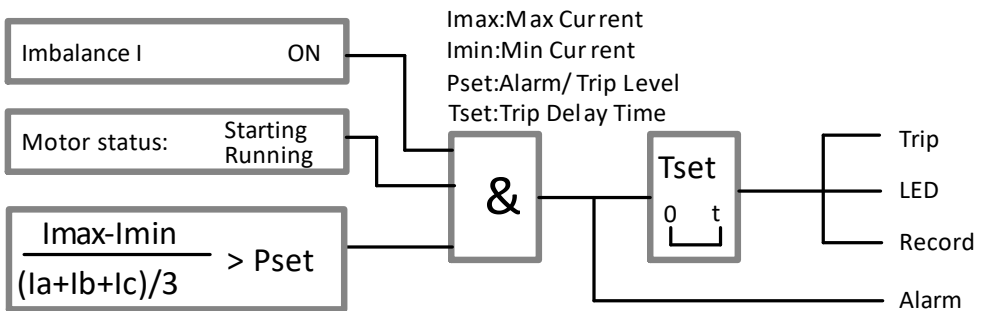

Figure 4. current imbalance protection logic

Parameter	Range	Default
Protection enable	OFF / Alarm / Trip / Alarm&Trip	Alarm&Trip
Alarm level	1.0% ~ 100.0%	15.0%
Trip level	1.0% ~ 100.0%	25.0%

Trip Delay-starting	0.1s ~ 600.0s	5.0s
Trip Delay-running	0.1s ~ 600.0s	3.0s

Table 10.Current unbalance protection related parameters

3.4 Phase Loss

Phase loss is an extreme expressive of the current imbalance. It cause serious heating of the rotor to burn and damage the motor. It accounts 30% of the motor damage by phase loss.

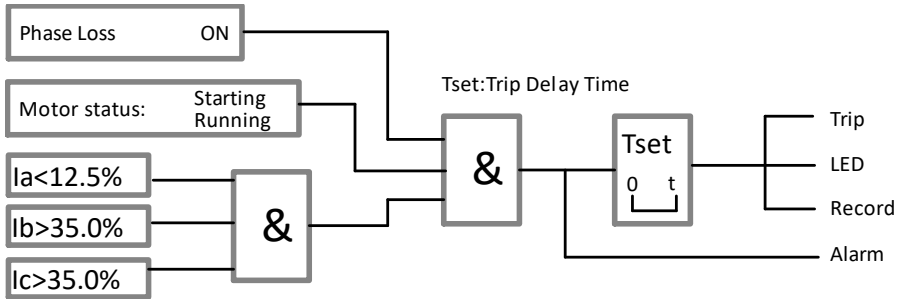

Figure 5.Current phase loss protection logic

Parameter	Range	Default
Protection enable	OFF/ Alarm / Trip	Trip
Trip delay-starting	0.1s ~ 600.0s	3.0s
Trip delay-running	0.1s ~ 600.0s	0.5s

Table 11.Phase loss protection related parameters

3.5 Under Load

Under load protection is particular for the abnormal sudden change cause by the under load of the motor such as the belt broken or water pump idling. Generally user could alarm such situation by configuration to remind the operator.

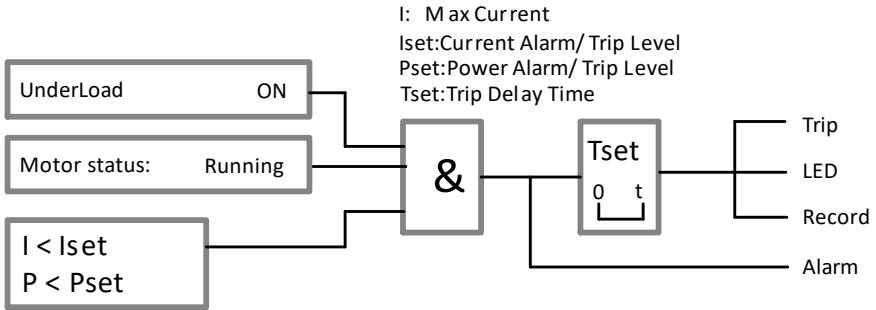

Figure 6.Under load protection logic

Parameter	Range	Default
Protection enable	OFF/ Alarm / Trip/ Alarm&Trip	OFF
Under load type	Current / Power	Current
Alarm level	5% ~ 100%Ie(Pe)	40%Ie
Trip level	5% ~ 100%Ie(Pe)	20%Ie
Trip delay time	0.1s ~ 600.0s	10.0s

Table 12.Underload protection related parameters

3.6 Jam Protection

Jam protection is a time over current protection during the running process of the motor by preventing serious jam or heat burn which cause by the motor over loading.

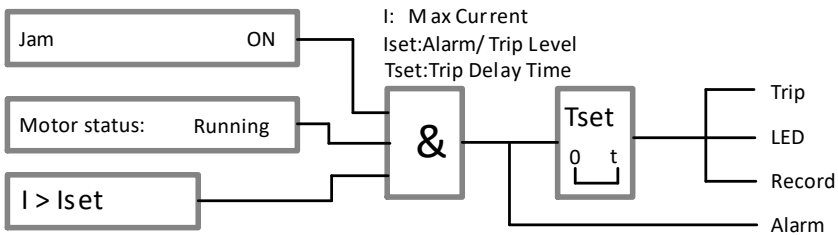

Figure 7.Jam protection logic

Parameter	Range	Default
Protection enable	OFF/ Alarm / trip / Alarm&Trip	Alarm&Trip
Alarm level	80%Ie ~ 1000%Ie	130%Ie
Trip level	80%Ie ~ 1000%Ie	150%Ie
Trip delay time	0.1s ~ 600.0s	2.0s

Table 13.Jam protection related parameters

3.7 Short-Circuit

Short-circuit protection preventing oversized fault current damage the motor. If the trip object refers to the circuit breaker, the controller will break the circuit breaker (instantly) when short-circuit was happened and break the contactor after 500ms.

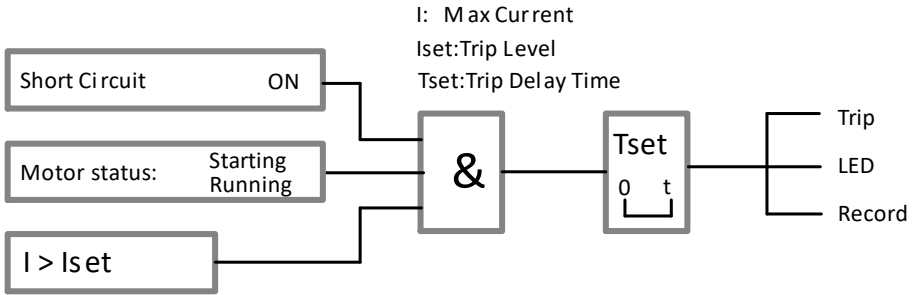

Figure 8.Short-circuit protection logic

Parameter	Range	Default
Protection enable	OFF / Alarm / Trip	OFF
Trip level-starting	100%I _e ~ 1000%I _e	700%I _e
Trip level -running	100%I _e ~ 1000%I _e	500%I _e
Trip delay-starting	0.0s ~ 600.0s	2.0s
Trip delay-running	0.0s ~ 600.0s	0.0s
Tripping object	Contactor / breaker	Circuit breaker

Table 14.Short circuit protection related parameters

3.8 Ground Fault

Ground fault protection is particular for the phase/line to the metal housing of the motor short-circuit fault. By using the ground current value (3-phase current vector) as time protection quantitative basis.

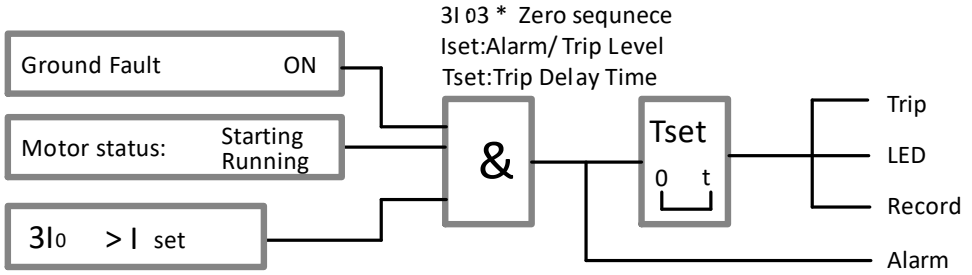

Figure 9. Single-phase ground fault protection logic

Parameter	Range	Default
Protection enable	OFF / Alarm / Trip / Alarm&Trip	OFF
Alarm Level	20%Ie ~ 1000%Ie	40%Ie
Trip Level	20%Ie ~ 1000%Ie	60%Ie
Trip delay-starting	0.0s ~ 600.0s	3.0s
Trip delay-running	0.0s ~ 600.0s	0.5s
Tripping object	Contactora / Breaker	Breaker

Table 15. Ground protection related parameters

3.9 Residual Current

When the application site requires more accurate ground fault detection, the residual current transformer is used to measure the ground current.

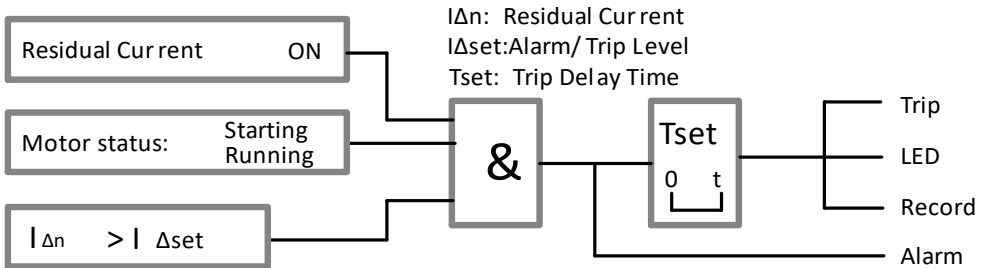

Figure 10. Residual Current protection logic

Parameter	Range	Default
Protection enable	OFF / Alarm / Trip / Alarm&Trip	OFF
Alarm level	20%IΔn ~ 1000%IΔn	30%IΔn
Trip level	20%IΔn ~ 1000%IΔn	50%IΔn
Trip delay-starting	0.0s ~ 600.0s	3.0s

Trip delay-running	0.0s ~ 600.0s	0.5s
Trip object	Contactora / Breaker	Breaker

Table 16. Residual Current protection related parameters

3.10 Start Overtime

Start over time protection will be implemented when proceeding start and exit from motor running automatically. The start overtime protection will be proceed when it detected the current is less than 10%Ie or more than the setting delay-running time after the start motion.

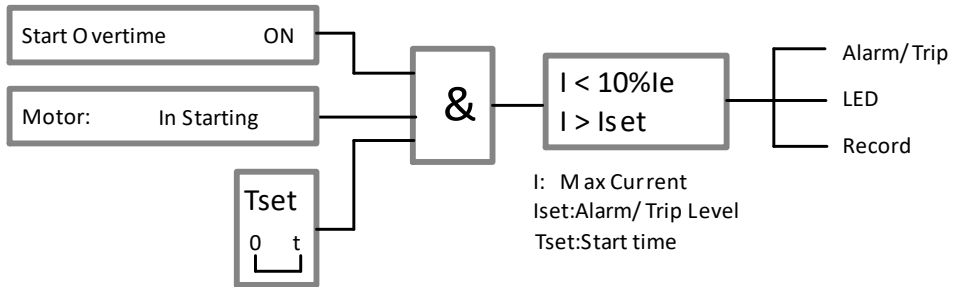

Figure 11. Star overtime protection logic

Parameter	Range	Default
Protection enable	OFF / Alarm/ Trip	Trip
Start time	1.0s ~ 600.0s	10.0s
Start overtime level	30%Ie ~ 300%Ie	110%Ie

Table 17. Start overtime protection related parameters

3.11 Phase sequence

Phase sequence will cause motor reversal

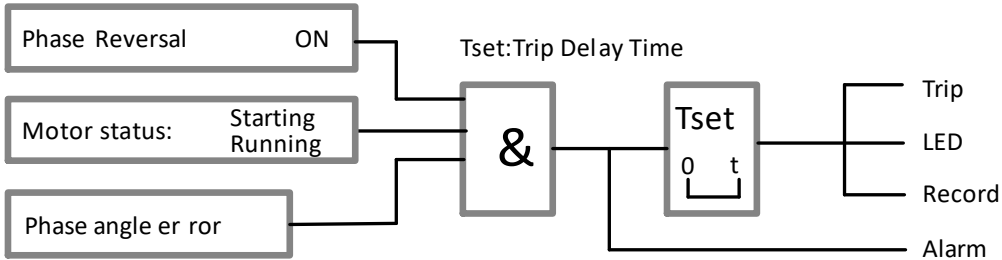

Figure 12.Voltage phase sequence protection logic

Parameter	Range	Default
Protection enable	OFF / Alarm / Trip	OFF
Trip delay time	0.0s ~ 5.0s	3.0s

Table 18.Voltage phase sequence protection related parameters

3.12 Under Voltage

Under voltage will cause the reduction of motor rotation speed and stop running, large current circuit break will cause voltage dip.

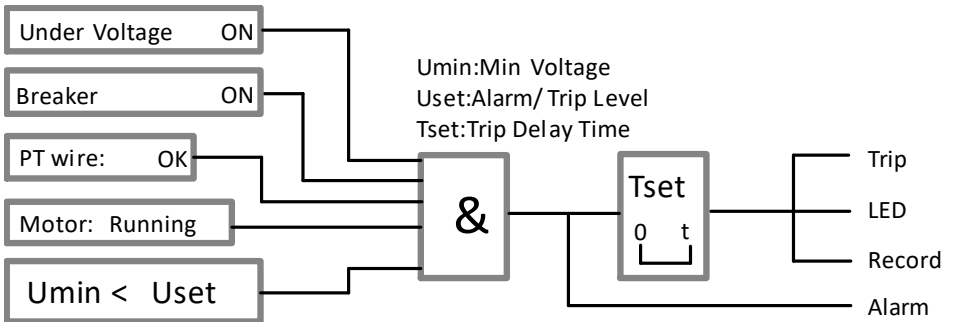

Figure 13.low voltage protection logic

Parameter	Range	Default
Protection enable	OFF / Alarm / Trip/ Alarm&Trip	OFF
Alarm level	45%Ue ~ 95%Ue	80%Ue
Trip level	45%Ue ~ 95%Ue	60%Ue
Trip delay time		5.0s

Tripping object	0.1s ~ 600.0s Contactor / Breaker	Breaker
-----------------	--------------------------------------	---------

Table 19.Under voltage protection related parameters

3.13 Over Voltage

Over voltage will cause motor isolation damage

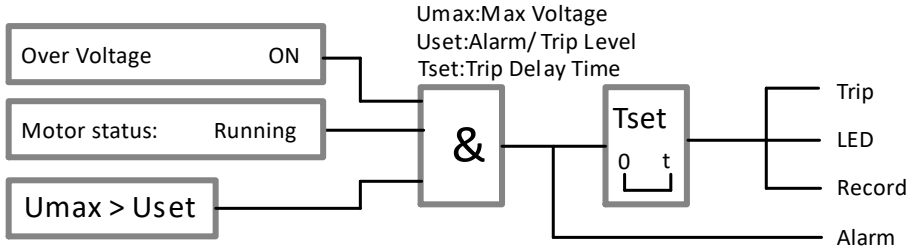

Figure 14.Over voltage protection logic

Parameter	Range	Default
Protection enable	OFF / Alarm/ Trip/ Alarm&Trip	OFF
Alarm level	100%Ue ~ 150%Ue	110%Ue
Trip Level	100%Ue ~ 150%Ue	120%Ue
Trip delay time	0.1s ~ 60.0s	5.0s

Table 20.Over voltage protection related parameters

3.14 Voltage Imbalance

Grid voltage instability will cause reduction of the motor rotation speed and stop running consequently.

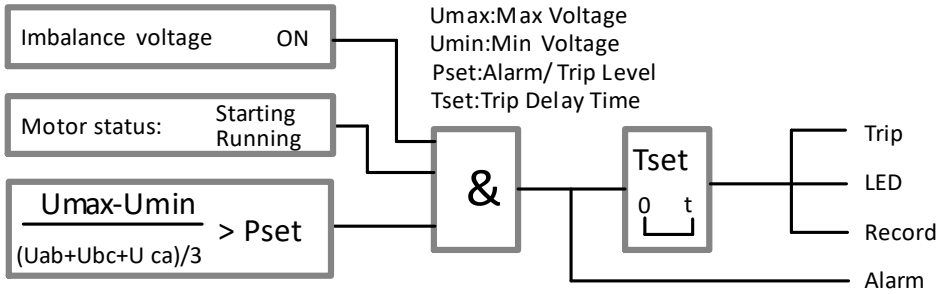

Figure 15.Voltage imbalance protection logic

Parameter	Range	Default
Protection enable	OFF / Alarm/ Trip / Alarm&Trip	Alarm&Trip
Alarm level	0.1% ~ 20.0%	3.0%
Trip level	0.1% ~ 20.0%	5.0%
Trip delay-starting	0.1s ~ 600.0s	3.0s
Trip delay-running	0.1s ~ 600.0s	1.0s

Table 21.voltage imbalance protection related parameters

3.15 PT Breaking

The primary or secondary fusing of the voltage transformer or loose contact will cause PT breaking. When the PT breaking alarm was tripping the low voltage protection will exit automatically.

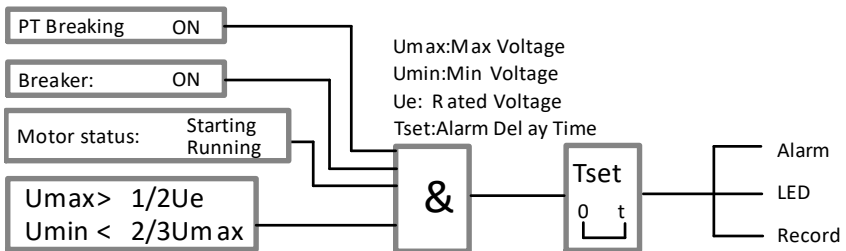

Figure 16.PT breaking protection logic

Parameter	Range	Default
Protection enable	OFF / Alarm	OFF
Trip delay time	0.1s ~ 60.0s	3.0s

Table 22.PT breaking protection related parameters

3.16 External Fault

External fault signal (such as temperature, liquid level) should connect to the DI input port and implement the tripping or alarm motion to fulfill the production continuity.

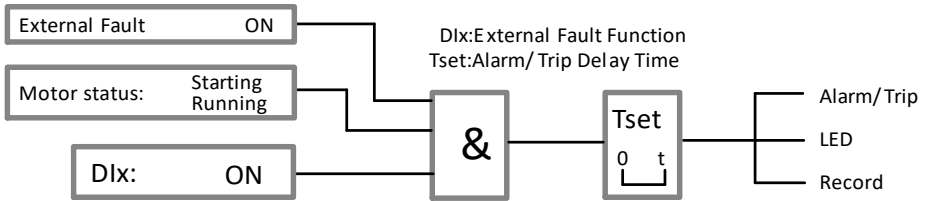

Parameter	Range	Default
Protection enable	OFF / Alarm/ Trip	OFF
Trip delay time	0.0s ~ 5.0s	3.0s
Trip reset mode	Manual / Auto	Manual

Table 23.External fault protection related parameters

3.17 Time tE (Increased Safety Motor)

Time tE protection comfort to the regulation of GB/T 3836.3-2000,it suitable for the increased safety motor .

Time tE protection fault must reset by manual

Overload protection is automatically turned off when tE time protection is active

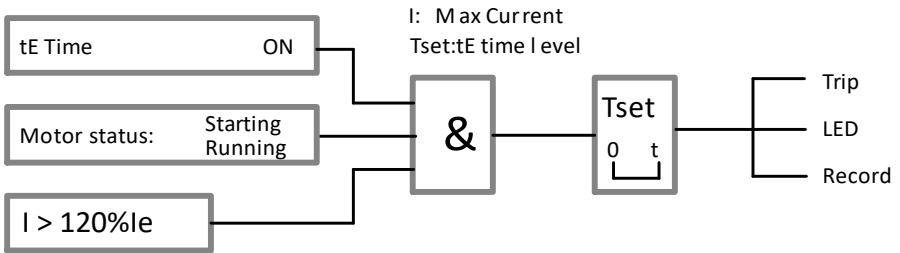
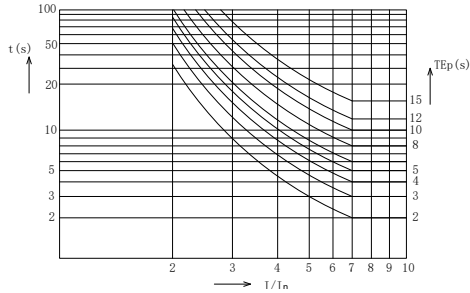

Figure 17.Time tE protection logic

Parameter	Range	Default
Protection enable	OFF / Trip	OFF
Time tE level	1.0s ~ 15.0s	5.0s

Table 24.tE time protection related parameters

3.18 Thermistor

The thermistor could receive 1 Thermistor input (pre-install in the winding or fixed in the distribution cabinet)for fulfill monitoring or protection function in which the working temperature or environmental temperature during the motor running

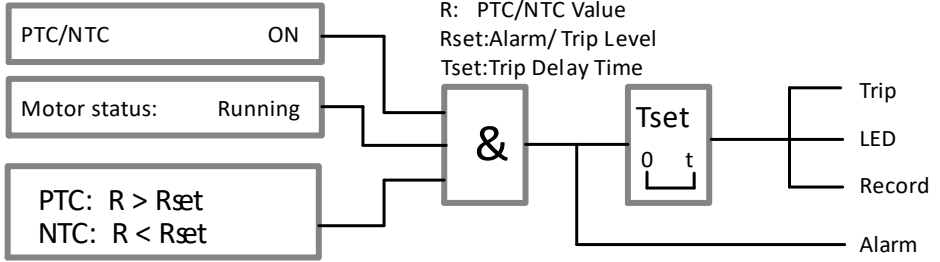

Figure 18. Thermistor tripping logic

Parameter	Range	Default
Protection enable	OFF/ Alarm / Trip / Alarm & Trip	OFF
Sensor type	PTC / NTC	PTC
Alarm level	0 ~ 10.00 kΩ	1.60 kΩ
Trip level	0 ~ 10.00 kΩ	3.60 kΩ
Allow reset level	0 ~ 10.00 kΩ	1.50 kΩ
Trip reset mode	Manual / Auto	Manual
Trip delay time	0.1s ~ 600.0s	3.0s

Table 25. thermistor protection related parameters

4. Motor control

4.1 Start/stop control logic

4.1.1 Command start and stop

Command start:

- The motor is ready to start
- The controller receives the start command (display module, input terminal, communication bus)
- Controller action relay, contactor pull-in, motor start

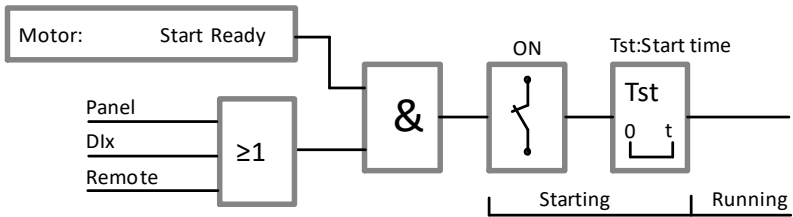

Figure 20. Start logic - normal start command

Command stop:

- The motor is running
- The controller receives the stop command (display module, input terminal, communication bus, fault trip)
- Controller disconnects relay, contactor is released, motor stop

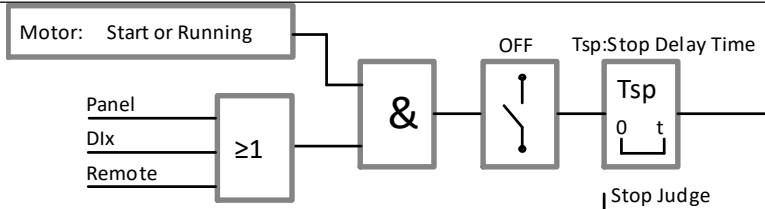

Figure 21. stop logic ---normal stop command

4.1.2 External bypass start/stop

If the external start/stop button does not go through the controller but connect to the contractor circuit directly, the controller will trace the current or the status of the contractor to judging the motor start or stop.

Note: In the thermal relay mode, the external bypass start and stop function is forced to be effective.

Related parameters	Explain	Range
Start/Stop Logic	Controller start and stop logic criterion source	0: current (10% Ie as the current start and stop criterion threshold) 1: Contactor (with the contactor change state as the start and stop criterion)
External Start	External bypass start permission enabled	0: OFF 1: ON
External Stop	External bypass stop permission enabled	0: OFF 1: ON

Bypass Start

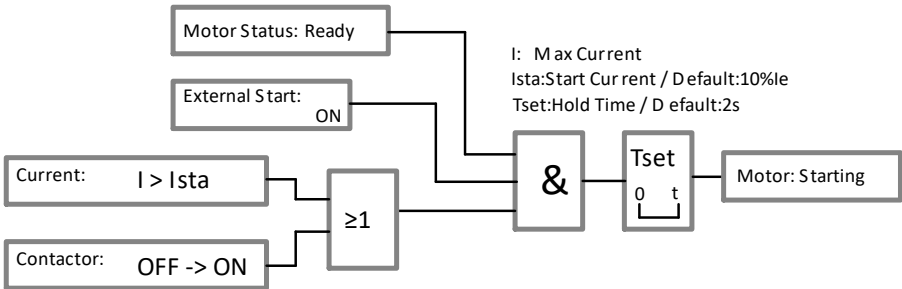

Figure 22. Start logic---bypass start

Bypass Stop

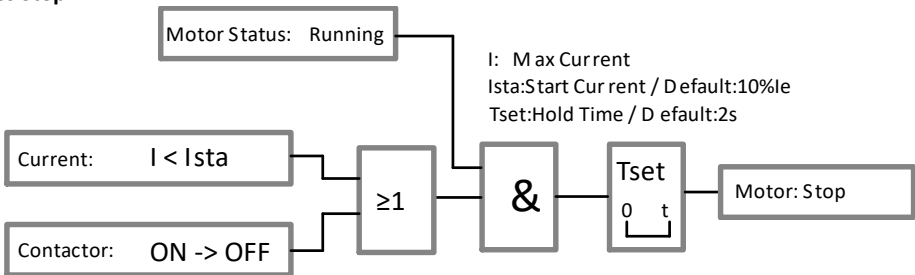

Figure 23. Stop logic ---bypass stop

4.2 Control authority

The WDH-31-531 defines local and remote control locations as described below:

Control position	Definition Description
Local	·Display panel ·DI terminals defined as local properties
Remote	·DI terminals defined as remote properties ·Communication bus

The user can select the currently active control position via "Control Rights".

Control authority option	Description	Effective control position
Local	Control position forced to be local	·Panel Position ·Local DI Position
Remote	The control location is forced to be remote	·Remote Comm ·Remote DI Position
DI-M1	Connect the 2-position switch to the DIx terminal, which is defined as the "L/ R Switch" function. Determined by the position of the transfer switch Local/remote status	Local: · Panel Position · Local DI Position Remote: · Remote Comm · Remote DI Position
DI-M2	No switch required Controlled by the DP master of the DCS system Local/Remote Status	Local: · Panel Position · Local DI Position Remote · Remote Comm

4.3 Power on self-starting

During the system power on process, the motor controller will judge whether allow self-starting to implement the self-starting the by time or by batches after power-up.

If the self-start is configured as “ON”, self-starting mode is configured as “Start” than the motor will be running by which the pre-setted time delay when power on.

If the self-start is configured as “ON”, self-starting mode is configured as “Resume” than the control system will consider the status before power off to decide whether restart or not. If the motor was at the running status before power off than it will self-starting according to the time delay regular after power on, if the motor was at the stop status before power off than the motor will not self-starting when the system is power on.

If the self-start is configured as “OFF”, self-star will be closed.

Parameter	Description	Range
Self-Start Enable	Self-Start enable	0: OFF 1: ON
Self-Start Mode	Self-Start working mode	0: Start 1: Resume
Self-Start Delay	Delay start time for batch starting	0~650.0s

Table 27.Self Start related parameters

4.4 Under voltage restart

4.4.1 Instant restart

When the main circuit was short circuit by lightning stroke or ground fault, the causes of dramatic grid voltage fluctuation in short-term was called power shaking. Normally the power shaking duration is less than 0.5S, the running motor could not stop completely by interface. The motor controller no need to tripping which ensuring the running breaker keep closing, the related contractor could close immediately.

4.4.2 Under voltage restart

If there is under voltage fault happened (below "Voltage Loss Level") during the motor was running, the motor will stop and the motor controller will accumulate the power off duration. When it detects the voltage of the motor return to the "Voltage Resume Level" or beyond, if the accumulate power off time duration is within the range of "Delay.U-Loss Time", the motor will delay restart as the setting command "Restart Delay Time", if the accumulate power off time is beyond limit, the motor will not restart again.

Note: The under voltage protection function is automatically turned off when the restart function is enabled.

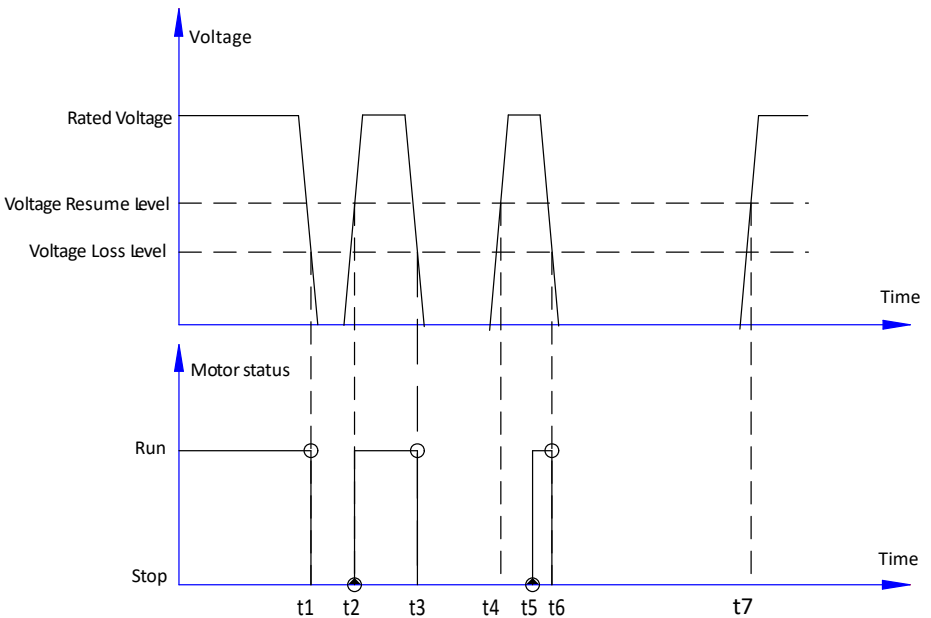

Restart instantly
<ul style="list-style-type: none"> · t1 voltage drop to power off threshold value · t2 voltage return to normal value of t1-t2is less than the power shaking time · execute instant restart: close the contactor immediately(without start process)

Restart delay
<ul style="list-style-type: none"> · t3 voltage drop to power off threshold value · t4 voltage return to normal, Value of (t3-t4)is more than Inst.U-Loss Time (instant restart is invalid) and value of (t3-t4) is less than Delay.U-Loss Time · Execute delay restart: t5 Restart Delay Time contactor close again, motor restart

Parameter	Explain	Range	Defaults
Instantly Restart	Under voltage Instantly Restart enable	0:OFF 1:ON	0
Delay Restart	Under voltage Delay Restart enable	0:OFF 1:ON	0
Voltage Loss Level	Restart drop voltage value	20~ 95%Ue	65
Voltage Resume Level	Restart recovery voltage value	20~ 95%Ue	85
Inst.U-Loss Time	Inst.U-Loss maximum Time	0.1 ~ 2.0s	0.5
Delay.U-Loss Time	Delay.U-Loss maximum Time	0.5 ~ 650.0s	3.0
Restart Delay Time	Restart Delay start Time	1.0 ~ 650.0s	10.0

Table 28.Under voltage Restart Related parameters

4.5 Analog Output

WDH-31-531 supports 2 channel 4-20mA analog output, various electric parameter is available and the output multiplying rate could be configured as well. The output multiplying rate means the corresponding rated value to 20mA (rated current or rated voltage is available)

Set the current measuring value is Xi, rated value is Xn, output multiplying rate is N, analog output value is Y, the computing formula is :

$$Y = 4mA + (Xi/Xn) \times 16mA / N$$

e.g.

Output electric parameter	Output multiplying rate	Measuring value /rated value	Analog output value
Ia	1.0	12.5A / 25A	4mA+(12.5/25)×16mA=12mA
Uab	2.0	190V / 380V	4mA+(190/380)×16mA=8mA

Table 29.Analog output value count example

4.6 Start mode

4.6.1 Thermal relay

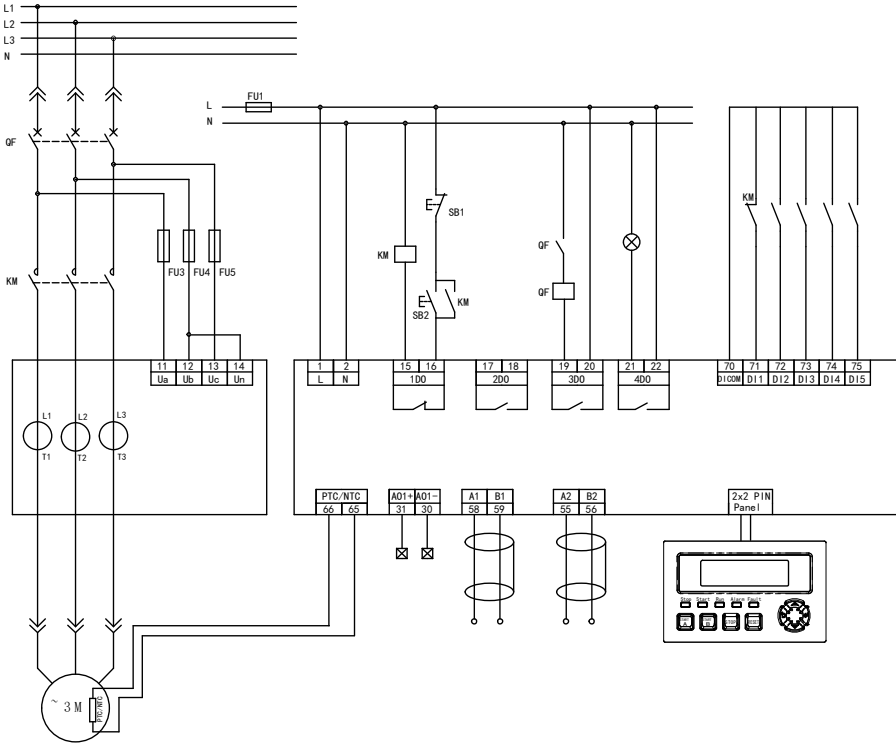

Under the thermal relay mode, WDH does not participate in the start and stop operation of motor (DI terminal and panel control are invalid).

- The start/stop running of the motor must implement by the Start/Stop external button
- As drawing shown, press the start button SB2, motor start, press stop button SB1, motor stop
- Protection trip relay 1DO is NC contract, when fault was detected, 1DO open, contactor(KM) off, motor will stop
- After fault reset, 1DO closed, allow the motor start again.

4.6.2 Direct start

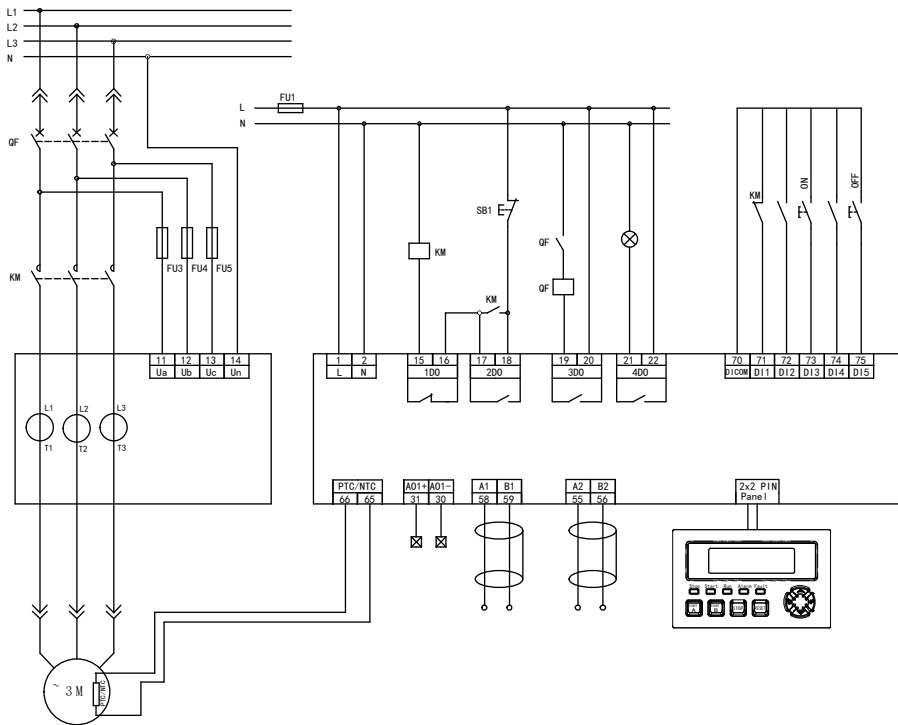

--Under the direct start mode, WDH controls the motor start/stop by relay 1DO(NC)/2DO(NO).

·As drawing shown, when the controller receive the start command(such as 3DI terminal or display interface), 2DO closed(pulse), contactor(KM) power on, motor start

·When the controller receives the stop command(such as 5DI terminal or display interface),1DO open(pulse), contractor KM power off, motor stop.

·When faults were detected,1DO open(level), contractor KM power off, motor stop.

·After reset, 1DO closed, controller allows the motor restart again.

4.6.3 Reversing

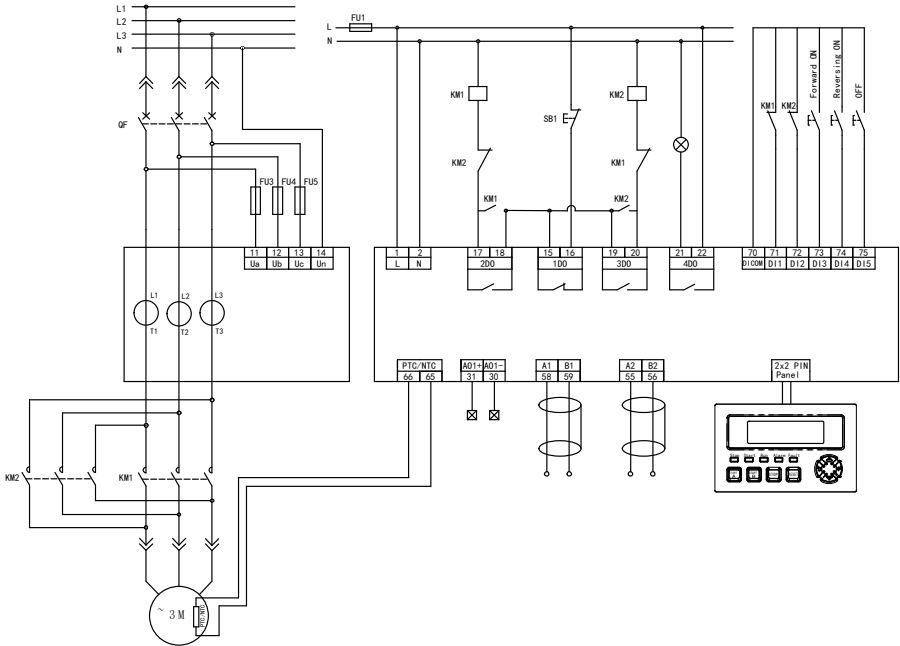

-Under the reversing mode (forward and reverse), WDH controls the motor forward rotation start/stop by relay 1DO(NC)/2DO(NO) and by relay 1DO (NC)/3DO(NO) to the reverse direction start/stop of the motor.

·As the drawing shown, when the controller receives the forward directional start command(such as 3DI terminal or display interface), 2DO closed(pulse), contactor KMI power on, the motor start with forward direction.

·When the controller receives the reverse direction start command (such as 4DI terminal or display interface), 3DO closed(pulse), contractor KM2 power on, the motor starts with reverse direction.

·When the controller receives the stop command (such as 5DI terminal or display interface), 1DO open (pulse), contractor KM1/2 power off, the motor stop.

·If enable “Continuous Switching”, if the current rotation direction is forward, the controller receives the reverse start signal, the motor will stop than delay 1s and start in reverse, or vice version.

4.6.4 Two speed start

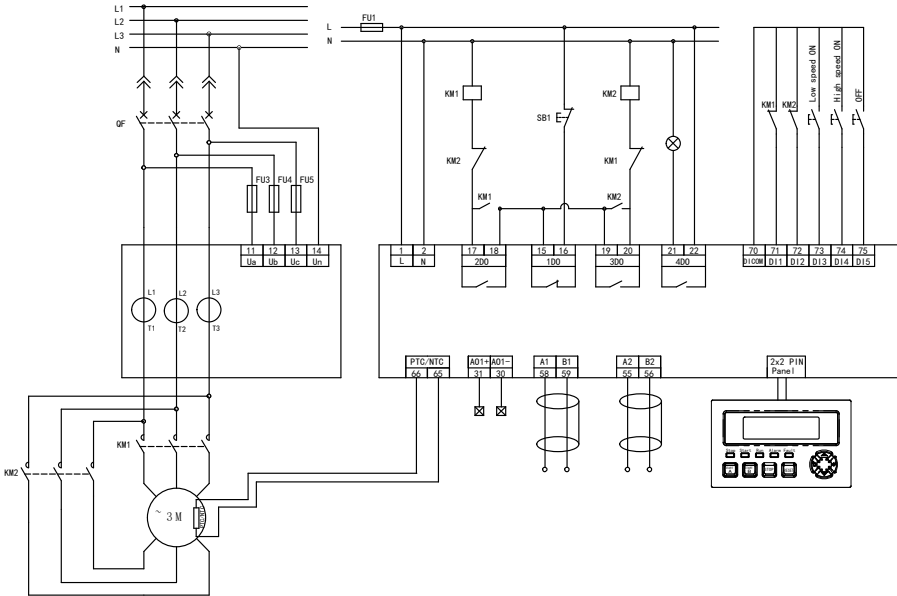

- In the two speed start mode, its control logic is same as the reversing start mode, WDH controls the motor with low speed start/stop by relay 1DO(NC)/2DO(NO) and the motor will start/stop with high speed by relay 1DO(NC)/3DO(NO)
- In the two speed start mode
- In the stop status, the motor could start with low speed;
- In the stop status, if enable “high speed direct start”, the motor could start with high speed;
- In low speed running, it could switch to high speed running(stop first and start with high speed after delay);
- In high speed running, switching to low speed running is prohibit;
- In high speed running, if enable” Fire Application”, all protection's “Trip” function is disabled.

4.6.5 Star Delta start

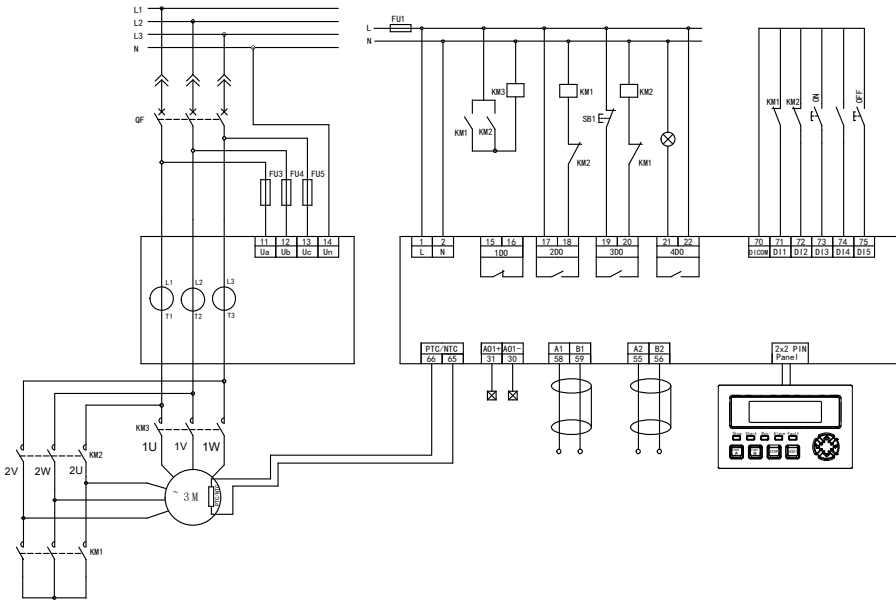

·In the star-Delta start mode(2 relays), controller command the motor to start in star mode by relay 2DO(NO), command the motor to start in delta start mode for running by relay 3DO(NO)

·As drawing shown, when the controller receives the start command(such as 3DI terminal or display interface), 2DO closed, contractor KM1/KM3 is power on, the motor was be at the star mode for start running, when the switch time is up, 2DO opened, KM1/KM3 power off and 3DO closed at the same time, when KM2/KM3 is power on, the motor will be at the delta start mode, when the starting was accomplished, the motor will be at normal status.

Action sequence of the contactor				
Contactor	start	switch		run
		1	2	
KM1	●	○	○	○
KM2	○	○	●	●

Star mode: 2U 2V 2W short circuit
 Delta mode: 1U--2V short circuit
 1V--2W short circuit
 1W--2U short circuit

5. Communication

5.1 RS485 network

The WDH main control module has a maximum of 2 RS485 communication interfaces and supports the standard Modbus-RTU protocol (corresponding model: WDH-31-533 / 534).

5.1.1 Network topology

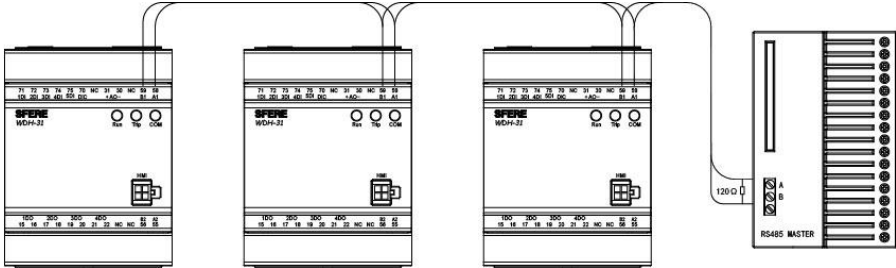

Figure RS485 line connection

5.1.2 Interface definition

<p>Terminal block 1: 71 72 73 74 75 70 NC 31 30 NC 59 58 1DI 2DI 3DI 4DI 5DI DIC +AO- B1 A1</p> <p>Indicators: Run, Trip, COM</p> <p>Terminal block 2: 1DO 2DO 3DO 4DO B2 A2 15 16 17 18 19 20 21 22 NC NC 56 55</p>	RS485-1 (Modbus-RTU)	
	58	A1
	59	B1
	RS485-2 (Modbus-RTU)	
	55	A2
	56	B2

5.1.3 Related parameters

Parameter name	Description	Options/Values	Default
Address 1	COMM 1 Address No	1~247	1

Baud rate1	COMM 1 Baud rate	0:4800 1:9600	1:9600
Data format1	COMM 1 data format	0:n.8.1 1:o.8.1 2:e.8.1 3:n.8.2	0:n.8.1

5.1.4 Modbus instruction sets

Modbus command	Modbus definition	WDH-31-530 definition
0x03/0x04	Read register value	<ul style="list-style-type: none"> ·Read the motor state information ·Read the motor running power value. ·Read the motor management information ·Read SOE event logging ·Read setting parameters
0x05	control a single coil	<ul style="list-style-type: none"> ·Start and stop control command ·Remote control single relay
0x06	Write a single register	<ul style="list-style-type: none"> ·Write setting parameters ·Start and stop control command ·Remote control single relay
0x10	Write multiple registers	<ul style="list-style-type: none"> ·Write setting parameters

6. Operation panel

6.1 Panel

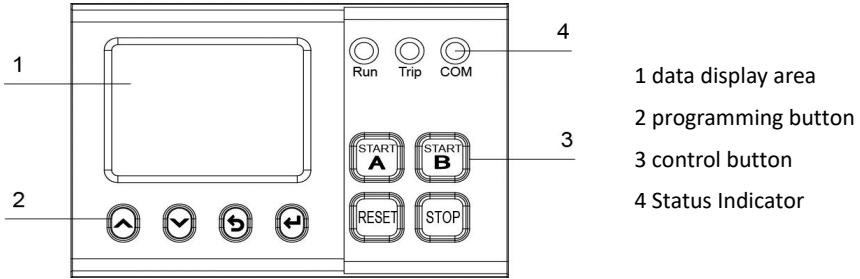

- 1 data display area
- 2 programming button
- 3 control button
- 4 Status Indicator

Control button	
START A	Forward start button/low speed start button
START B	Reverse start button / high speed start button
STOP	Stop button
RESET	Fault reset button

Programming button		
	Return	<ul style="list-style-type: none"> ·Cancel/Exit ·Return to menu focus ·Return to the previous menu
	Enter	<ul style="list-style-type: none"> ·Enter ·Enter the data focus ·Enter into next menu
	Up	<ul style="list-style-type: none"> ·Menu item shifting ·Data shifting ·Modify the value (increase)
	Down	<ul style="list-style-type: none"> ·Menu item shifting ·Data shifting ·Modify the value (decrease)

Status Indicator		
Run	Green	Lightning: Stop Flicker: Running
Trip	Red	Lightning: Fault trip Flicker: Alarm
COM	Green	Flicker: Communication data interaction

6.2 Control interface

In the control interface, user could command the start/stop order by control button, take the direct start as example:

Start by Panel:

- ◆ The operation panel displays "Ready to start", and this window contains information: start mode (such as direct start), control authority (such as local)
- ◆ Press the "START A" button to enter "Start running confirmation"
- ◆ Press "←" to confirm execution
- ◆ Enter the "start state"
- ◆ After the start time is up, it will automatically enter the "running state"
- ◆ Complete panel startup

Stop by Panel:

- ◆ Control panel display "starting status" or "running status"
- ◆ Press the "STOP" button to enter "Stop running confirmation"
- ◆ Press "←" to confirm execution
- ◆ After completing the stop logic, it automatically returns to "Ready to start"
- ◆ Complete panel stop

Panel fault reset

- ◆ Panel interface display "Fault status"
- ◆ Press the "RESET" button
- ◆ Press "←" to confirm execution
- ◆ After completing the reset logic, it automatically returns to "Ready to start"
- ◆ Complete panel reset

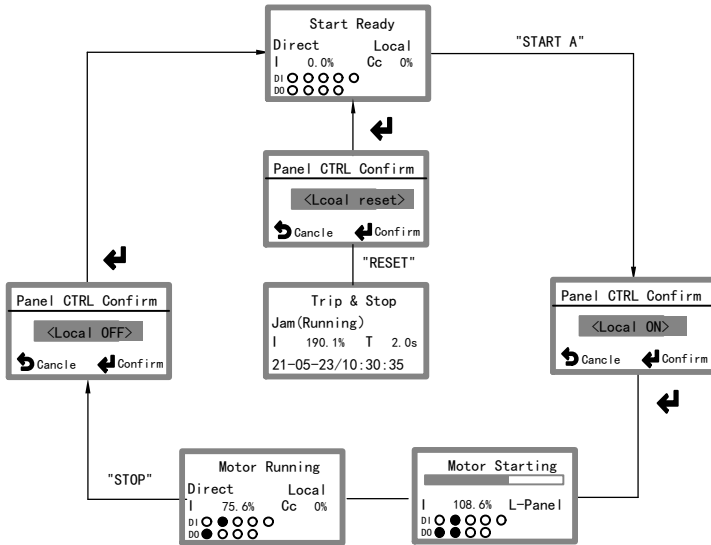

6.3 Query interface

Under the control interface, press "←" to enter the query interface and press "↵" to return.

In the query interface, there are menu items such as "motor operation data", "real-time alarm information", "history query", "management information query", "user parameter configuration", "factory configuration", which can be selected by pressing the "▲" and "▼" keys. After selecting the menu item, click the "←" key to enter the next menu and display more related information.

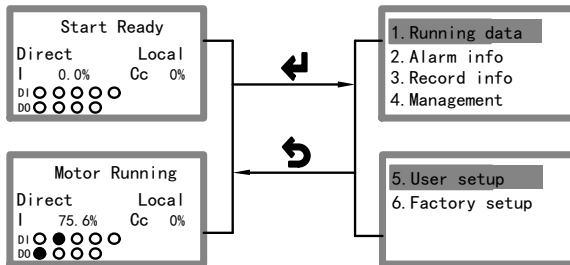

6.3.1 Running data

“Running data” includes electric energy parameter data, power data, I/O status, etc.

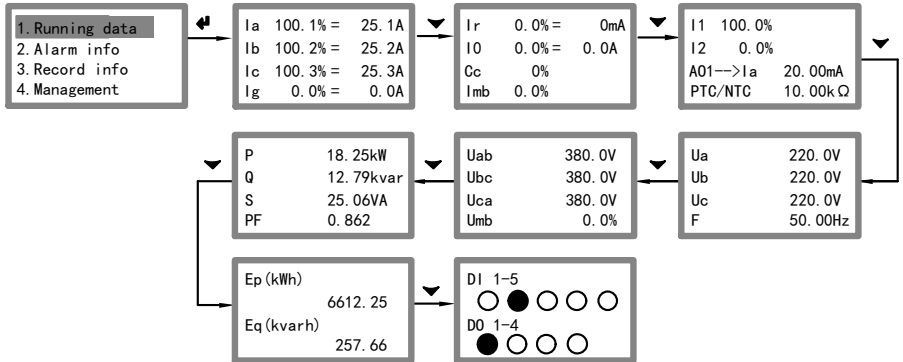

Running Data Prompt Instructions			
I	3-phase maximum current %	Td	Fault trip delay time
Ia	Phase-A current (%)	Ua	Phase-A voltage value
Ib	Phase-B current (%)	Ub	Phase-B voltage value
Ic	Phase-C current (%)	Uc	Phase-C voltage value
Ig	Ground current (%)	Uab	AB line voltage value
Ir	Residual current (%)	Ubc	BC line voltage value
I0	Zero-sequence current (%)	Uca	CA line voltage value
F	Grid frequency	Unb	Voltage imbalance value
Cc	Thermal capacity(%)	P	Total active power
Inb	Current imbalance level	Q	Total reactive power
AO1	1#analog output value	S	total apparent power
PTC	Thermistor value	PF	total power factor
Ep	Total active energy	Eq	total reactive energy
DI(n)	The (nth) DI signal status	DO(n)	ON/OFF state of the (nth) relay
○	Digital input --- no signal	●	Digital input --- with signal
	Relay status --- OFF		Relay Status --- ON

Running Data Prompt Instructions

6.3.2 Alarm

In "Alarm", you can view the current related real-time alarm information.

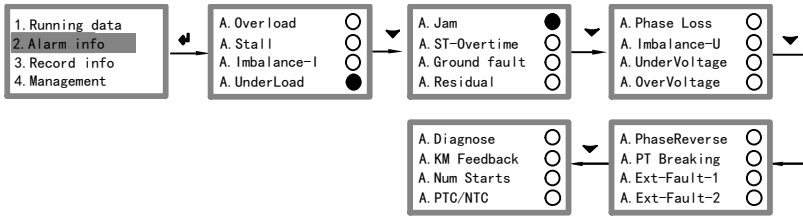

6.3.3 Record

"Record" includes "Trip record", "Alarm record", "Start record", "Stop record", "DI switch record", "Reset record", select the corresponding query times to display the current detailed record information.

Select the number of records to view by pressing the "▲" and "▼" keys

For fault and alarm records, the details of the current record number can be switched through the "←" key

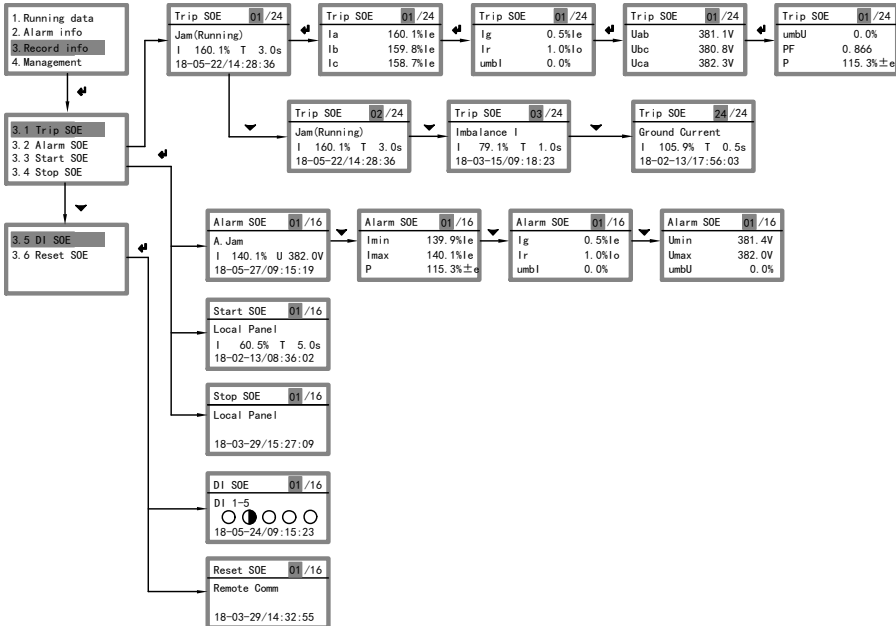

Record query prompt description			
I	3-phase current %(max)	U	Line Voltage(Max)
Imin	3-phase current %(min)	Umin	Line Voltage(Min)
Imax	3-phase current %(max)	Umax	Line Voltage(Max)
Inb	Current imbalance	Unb	Voltage imbalance
T	Start time		Dlx 0->1
Td	Fault trip delay time		Dlx 1->0
R	PTC/NTC Thermal resistance value		

6.3.4 Maintenance information

“Maintenance” includes relevant motor running data and other information.

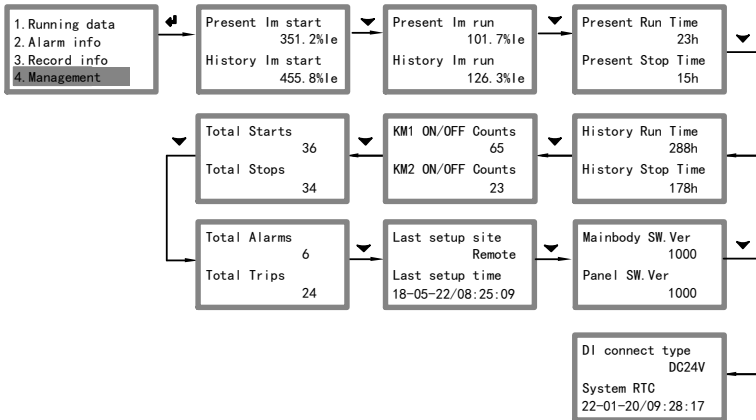

6.4 Setting interface

Enter into the setting interface

- ◆ Select "Setup"
- ◆ Press the "←" button to enter in "password->setup"
- ◆ Enter the correct password through the "▲" and "▼" buttons, (the default is 0001)
- ◆ Press the "←" button to enter the setup interface

Exit the setting interface

- ◆ In the main menu of the setting interface, press the "↶" button to enter the "parameter save"
- ◆ Select "YES"/"NO" through the "▲", "▼" buttons, whether to save the modification
- ◆ Press "←" button to return to the query interface

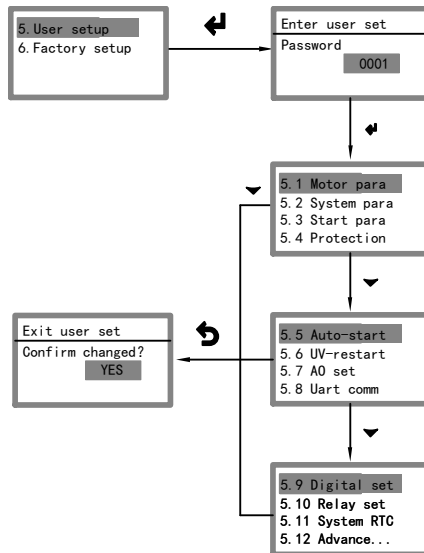

6.4.1 Basic setup

Select "Basic Setup" and press "←" to enter. Press the "←" button in the selected corresponding menu item to enter the setting value associated with the menu, and the value (or option) can be modified by the "▲" and "▼" buttons.

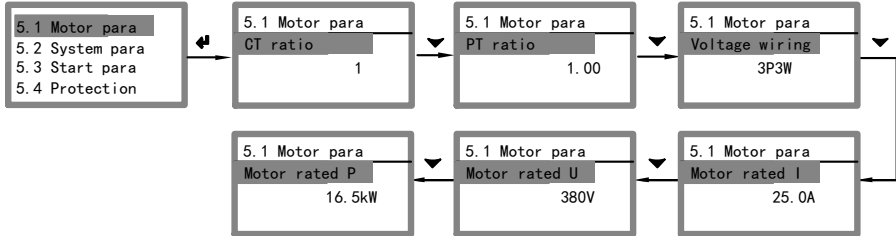

Name	Range	Default
CT Ratio	1 ~ 9999	1
PT Ratio	1.00 ~ 20.00	1.00
Wiring Mode	0: 3P4W 1: 3P3W 2: 1P2W	0
Motor rated current	0.1 ~ 2500.0 A	5.0
Motor rated voltage	100 ~ 1200V	380
Motor rated Power	0.1 ~ 2000.0 kW	3.3

6.4.2 System Setup

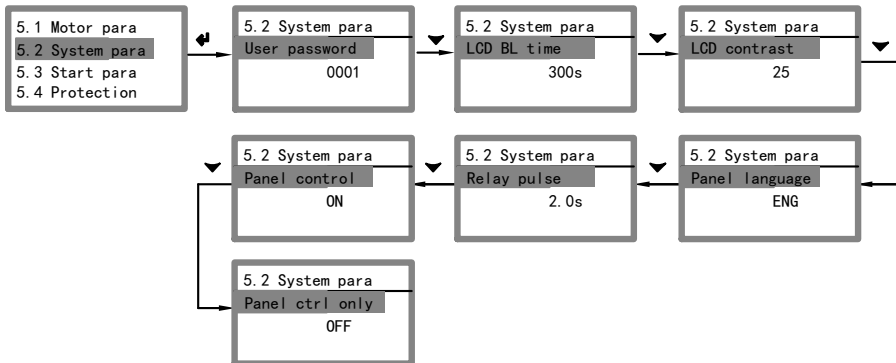

Name	Range	Default
User Password	0000 ~ 9999	1
LCD Backlight	0: OFF (Normal light) 1: 60s 2: 180s 3: 300s	2

LCD contrast	25~55	38
Language	0: Chinese 1: English	0
DO Pulse Width	0 ~ 60.0s	2.0
Panel control enables	0: Invalid (no panel start/stop) 1: valid	1
Panel independent control	0: Invalid 1: Valid(only panel valid, all other locations are prohibited)	0

6.4.3 Start control

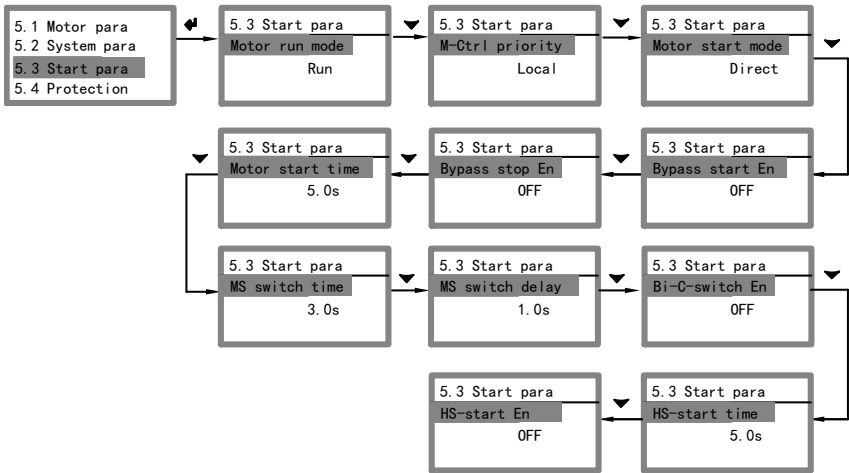

Name	Range	Default
Motor operation mode	0: operation (normal operation mode) 1: Test (the protection function is turned off for debugging the control circuit) 2: Automatic (if the circuit breaker is in the closing position, the operation mode; if the circuit breaker is in the opening position, the test mode.)	0
Motor control authority	0: Local 1: Remote 2: DI (DI-M1) 3: AT (DI-M2)	0
Motor starting mode	0: Direct start 1: Reversing start 2: Two-speed start 3: Star/delta	0

	4: Protected mode	
External bypass start	0: Invalid 1: valid	1
External bypass stop	0: Invalid 1: valid	1
Motor start time	0.1~600.0 s	5.0
Start Switch Time	0.1~600.0 s For example: in star-delta starting, switching time is the star time	3.0
Switch Time Delay	0.1~600.0 s For example: after star start, delta start after delay	1.0
Two-way continuous switch	0: Invalid 1: valid	0
High Speed Start Time	0.1~600.0 s	5.0
High Speed Direct Start	0: OFF 1: ON	0

6.4.4 Protection Setup

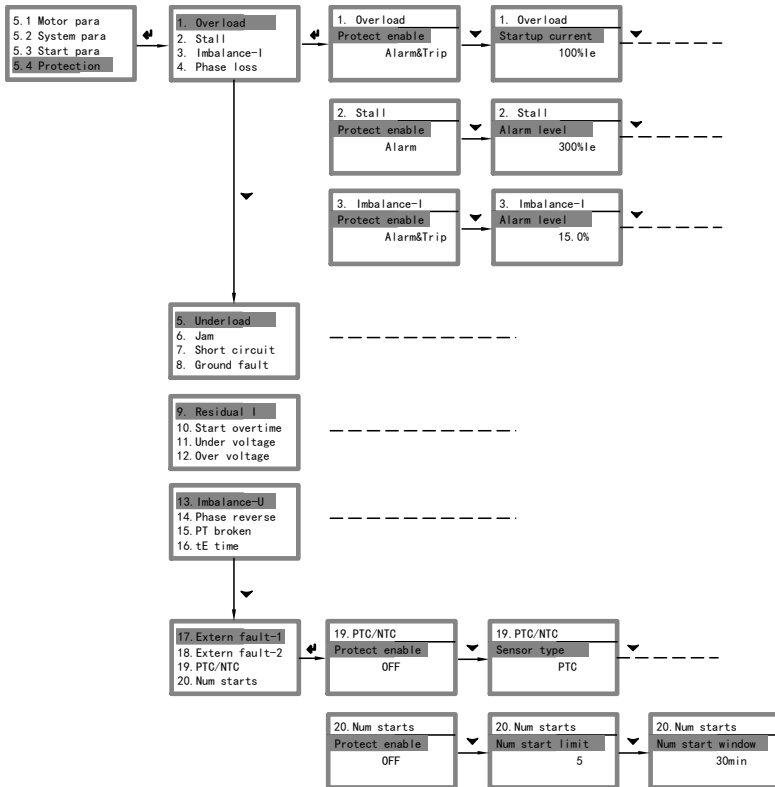

Please refer to Chapter 3 for the description of protection related parameters.

6.4.5 Self-start Setup

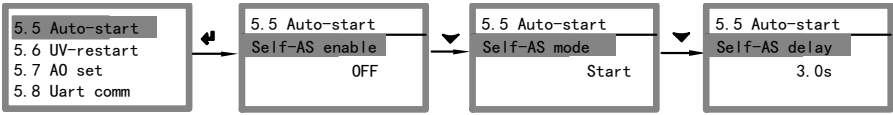

<Please refer to Chapter 4.3 for the description of parameters >

6.4.6 Restart Setup

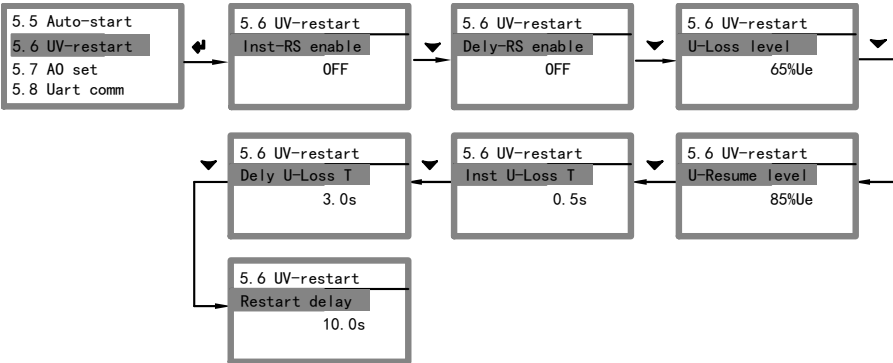

<Please refer to Chapter 4.4 for the description of parameters >

6.4.7 Analog output Setup

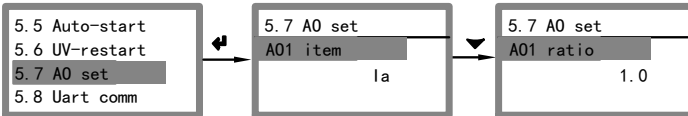

Name	Range	Default	
Analog output 1 signal	0:Ia 1:Ib 2:Ic 3:Imax 4:Iavg 5:Uab	6:Ubc 7:Uca 8:Umax 9:Uavg 10:Freq 11:Power	0
Analog output 1 rating	1.0~10.0	1.0	

6.4.8 Communication Setup

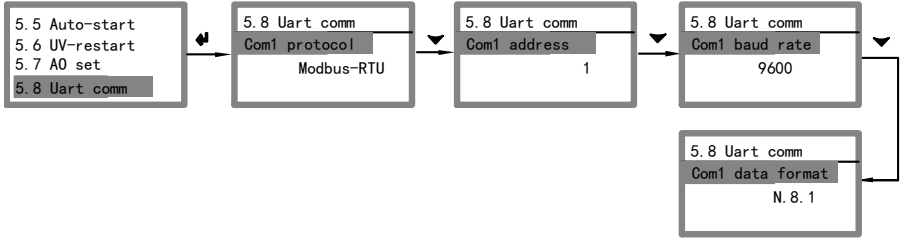

Name	Range	Default
COM1 Protocol	0: Modbus 1:Profibus	0
COM1 Address	1~247	1
COM1 Baud Rate	0:4800 1:9600	1
COM1 Data Format	0:n.8.1 1:o.8.1 2:e.8.1 3:n.8.2	0

6.4.9 Digital input Setup

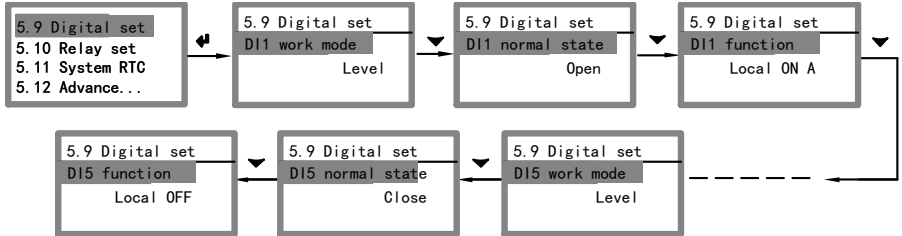

Name	Range	Default
DI (n) mode	0: Level 1: Pulse	0 (force)
DI (n) Normal State	0: NO (Open) 1: NC (Close)	0
DI (n) Item	0: Contactor A 1: Contactor B 2: Contactor C 3: Breaker 4: Local Start A 5: Local Start B 6: Local Stop 7: Local Reset	24

- 8: Local STA/STP A
- 9: Local STA/STP B
- 10: Remote Start A
- 11: Remote Start B
- 12: Remote Stop
- 13: Remote Reset
- 14: Remote STA/STP A
- 15: Remote STA/STP B
- 16: Emergency Stop
- 17: Emergency Reset
- 18: Interlock Stop A
- 19: Interlock Stop B
- 20: External Fault 1
- 21: External Fault 2
- 22: L/R Switch
- 23: Complex Switch
- 24: General DI
- 25: Softer Run State
- 26: Fire STA/STP A
- 27: Fire STA/STP B
- 28: Protection OFF

6.4.10 Digital output Setup

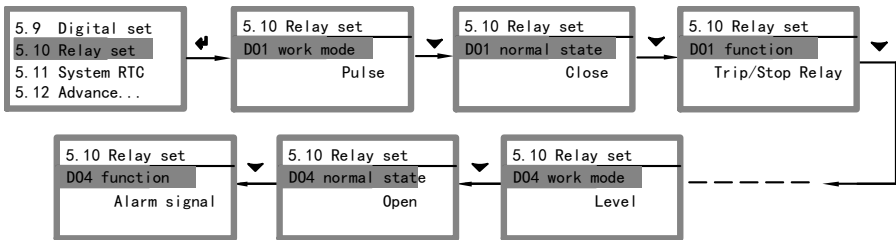

Name	Range	Default
DO (n) Mode	0: level 1: pulse	0
DO (n) Normal State	0: NO (Open) 1: NC (Close)	0
DO (n) Item	0: Start A relay 1: Start B relay 2: Start C relay 3: Trip protection 4: Short circuit fault 5: Self-diagnostic output 6: Device is ready for output	12

- 7: Remote ready output
- 8: Remote control output
- 9: Running signal output
- 10: Total alarm signal
- 11: Total fault signal
- 12: General DO output
- 13: Overload trip
- 14: Stall trip
- 15: Current unbalance
- 16: Under load trip
- 17: Jam trip
- 18: Single-phase ground trip
- 19: Residual current trip
- 20: Under voltage trip
- 21: Overvoltage trip
- 22: Phase loss trip
- 23: Thermistor trips
- 24: Reserved
- 25: External fault 1 trip
- 26: External fault 2 trip
- 27: Single-phase grounding alarm
- 28: Residual current alarm
- 29: Thermistor alarm
- 30: Reserved

6.4.11 System clock

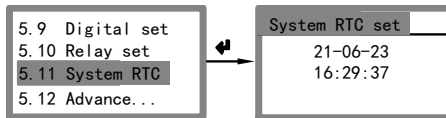

6.4.12 Advanced control setup

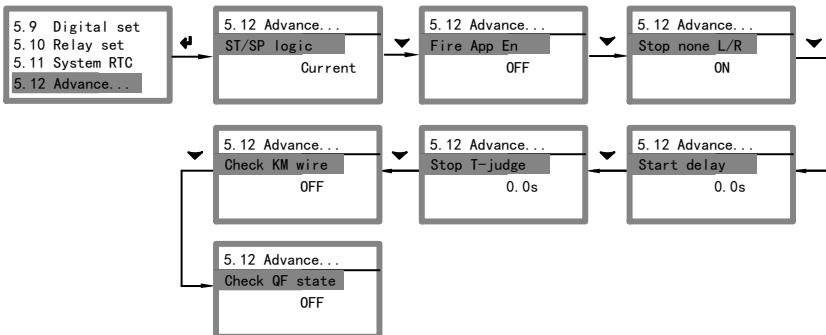

Name	Range	Default
Start/Stop Logic	0: current (10% I _e as the current start and stop criterion threshold) 1: Contactor (with the contactor change state as the start and stop criterion)	0
Fire Application	0: OFF 1: ON(measurement control mode) Two-speed start mode, if the fire circuit is effective, the protection is effective at low speed operation and the protection is closed at high speed. In other starting modes, if the fire circuit is valid, the protection is turned off (the trip is invalid and the alarm is valid).	0
Stop Priority	0: OFF (stop is not controlled by permission, such as remote location, local button can also stop) 1:ON (stop is controlled by authority, such as remote locations, the local button disabled)	1
Start Delay Time	0 ~ 600.0s The panel start is invalid, only for the DI terminal or communication start.	0
Stop Judge Time	0 ~ 10.0s (0: Turn off this feature) Current Criterion: If the stop command is received, if the current is higher than 10% I _e after the delay, the stop will fail. Contactor criterion: If the stop command is received, if the contactor is not divided after the delay, the stop will fail.	0
Breaker Monitor	0: OFF 1: ON (the circuit breaker is in the joint position, the starting operation is valid)	0
Contactor Monitor	0: OFF 1: ON Valid only for current criteria. Check the contactor status during the start and stop process, if not, give an alarm.	0

7. Fault detail

When the WDH detects a fault signal, the fault will remain (latched) until the fault reset command is received.

WDH can make fault indication in the following ways:

- ◆ Main control module Trip indicator is always on
- ◆ The main module is defined as the relay action of "total fault signal"
- ◆ The corresponding fault information is displayed on the display module screen

LCD display description	Code	Source	Possible reasons
Overload fault	1	Load	Trip due to thermal overload of the motor Check the overload protection trip level Check if the motor power is too small
Stall (Starting) fault	2	Load	Excessive current during motor start Check the motor for mechanical problems Check if the load is too heavy
Imbalance I	3	Power supply load contactor	One phase current is too low Check if the grid voltage is stable Check if the current terminals are reliable
Under Load fault	4	Load	Load current or power is too low Check if the pump is idling Check if the conveyor belt is broken
Jam(Running) fault	5	Load	Excessive current during motor operation Check the motor for mechanical failure Check if the load is too heavy
Ground Current fault	6	Load	At least one phase is connected to the ground Check motor wiring Check motor insulation
Residual Current fault	7	Load	At least one phase is connected to the ground Check motor wiring Check motor insulation
Start Overtime fault	8	Load	Light load or heavy load operation after motor start Check motor load Check if the motor starting time is too short
Phase Loss fault	9	Power supply load contactor	At least one phase current is too low Check if the grid voltage is stable Check if the current terminals are reliable Check contactor contacts for wear
Short Circuit fault	10	Power supply	At least one phase current is too low

		load	Check if the grid voltage is stable Check if the current terminals are reliable Check contactor contacts for wear
Under Voltage fault	11	Power supply	Check if the grid voltage is too low Check voltage wiring Check if the fuse is normal
Over Voltage fault	12	Power supply	Check if the grid voltage is too high Check voltage wiring
Imbalance U	13	Power supply	Check if the grid voltage is stable Check if the fuse is normal
PT Breaking alarm	14	Power supply	Check if the grid voltage is stable Check if the fuse is normal
Phase sequence fault	15	Power supply	Check voltage wiring
External Fault 1	16	Custom	Check the external input signal
External Fault 2	17	Custom	Check the external input signal
tE Fault	20	Load	Trip due to motor overload Check tE protection trip level Check if the motor power is too small
Stop fail fault	21	Contactor	Current is also detected after stop operation Check if the contactor wiring is reliable Check contactor contacts for wear
Start fail alarm	--	Circuit breaker contactor	Received start command, but contactor and circuit breaker are not in normal state Check if the circuit breaker is in position Check if the contactor is in the grading
Self Diagnose alarm	--	Device itself	Equipment hardware failure
Contactor State alarm	--	Contactor	Contactor auxiliary contact feedback error Check contactor wiring

8. Technical data

System parameter		
Rated voltage of motor	AC400V or AC690V, 50/60Hz	
Rated current of motor	0.1 A ~ 800 A	
Insulation resistance	≥100MΩ	
Device auxiliary power supply		
Working range	AC/DC 80~270V	
Power consumption	< 10VA	
Use environment		
Environment temperature	-20℃ ~ +60℃	
Relative humidity	≤93%RH	
storage temperature	-40℃ ~ 70℃	
Protection level	Measurement module/master control module: IP20 Display panel: IP64	
Withstand voltage characteristics	AC2kV/1min	
Protection action accuracy		
Current/voltage starting value	set value±1%	
Heat capacity accumulation value	set value±1%	
Delay action time	Delay action setting value < 2s: ±100mS Delay action setting value ≥ 2s: ±5%	
Relay output		
Control relay contact capacity	AC250V/5A (Resistive) AC250V/0.5A (Sensibility) DC30V/5A (Resistive)	
Maximum break voltage	AC400V	
Maximum break capacity	1000VA	
Action time	10ms	
Mechanical life	>1000000	
DC24V Switch input		
Node type	Dry contact	
Electrical isolation	Opto-isolated inputs	
Internal voltage	DC24V	
Input resistance	5kΩ	
On current	1.5mA	
The sampling period	2mS	
Analog output		
Output type	DC 4~20mA	
Response time	< 100mS	
load	R _L ≤ 350Ω	
EMC Electromagnetic Compatibility Characteristics		
Electrostatic discharge immunity	IEC 61000-4-2	Level 3
Electrical fast transients/bursts immunity	IEC 61000-4-4	Level 3
Surge immunity	IEC 61000-4-5	Level 3

Oscillation waves immunity	IEC 61000-4-12	Level 3
Radio-frequency field immunity	IEC 61000-4-3	Level 3
Conducted RF disturbances immunity	IEC 61000-4-6	Level 3
Power frequency magnetic fields immunity	IEC 61000-4-8	Class A
Voltage dips and short interruptions	IEC 61000-4-11	Level 3
Radiated & Conducted Emissions	CISPR22	Class A
Reference Standard		
Low-voltage switchgear and controlgear	Part1:General rules	IEC 60947-1
Low-voltage switchgear and controlgear	Part 4-1: Contactors and motor-starters	IEC 60947-4-1
---Electromechanical contactors and motor-starters(Including motor protector)		

9. Appendix

9.1 Overload protection time characteristic table

$K I/I_q$	10	25	60	75	100	125	250	300	500	750	1000	1200
1.1	47.6 2	119.0 5	285.7 1	357.1 4	476.1 9	595.2 4	1190.4 8	1428.5 7	2380.9 5	3571.4 3	4761.9 0	5714.2 8
1.2	22.7 3	56.82	136.3 6	170.4 5	227.2 7	284.0 9	568.18	681.82	1136.3 6	1704.5 5	2272.7 3	2727.2 7
1.3	14.4 9	36.23	86.96	108.7 0	144.9 3	181.1 6	362.32	434.78	724.64	1086.9 6	1449.2 8	1739.1 3
1.4	10.4 2	26.04	62.50	78.13	104.1 7	130.2 1	260.42	312.50	520.83	781.25	1041.6 7	1250.0 0
1.5	8.00	20.00	48.00	60.00	80.00	100.0 0	200.00	240.00	400.00	600.00	800.00	960.00
2.0	3.33	8.33	20.00	25.00	33.33	41.67	83.33	100.00	166.67	250.00	333.33	400.00
2.5	1.90	4.76	11.43	14.29	19.05	23.81	47.62	57.14	95.24	142.86	190.48	228.57
3.0	1.25	3.13	7.50	9.38	12.50	15.63	31.25	37.50	62.50	93.75	125.00	150.00
3.5	0.89	2.22	5.33	6.67	8.89	11.11	22.22	26.67	44.44	66.67	88.89	106.67
4.0	0.67	1.67	4.00	5.00	6.67	8.33	16.67	20.00	33.33	50.00	66.67	80.00
4.5	0.52	1.30	3.12	3.90	5.19	6.49	12.99	15.58	25.97	38.96	51.95	62.34
5.0	0.42	1.04	2.50	3.13	4.17	5.21	10.42	12.50	20.83	31.25	41.67	50.00
5.5	0.34	0.85	2.05	2.56	3.42	4.27	8.55	10.26	17.09	25.64	34.19	41.03
6.0	0.29	0.71	1.71	2.14	2.86	3.57	7.14	8.57	14.29	21.43	28.57	34.29
6.5	0.24	0.61	1.45	1.82	2.42	3.03	6.06	7.27	12.12	18.18	24.24	29.09
7.0	0.21	0.52	1.25	1.56	2.08	2.60	5.21	6.25	10.42	15.63	20.83	25.00
7.2	0.20	0.49	1.18	1.48	1.97	2.46	4.92	5.90	9.83	14.75	19.67	23.60
7.5	0.18	0.45	1.09	1.36	1.81	2.26	4.52	5.43	9.05	13.57	18.10	21.72
8.0	0.16	0.40	0.95	1.19	1.59	1.98	3.97	4.76	7.94	11.90	15.87	19.05

9.2 tE Time Protection Characteristic Table

I/I_e	t_{Ep}	1.0(s)	4.0(s)	4.3(s)	4.6(s)	5.0(s)	5.5(s)	6.0(s)	15.0(s)
3.00	4.00	16.00	17.20	18.40	20.00	22.00	24.00	60.00	
3.20	3.48	13.92	14.96	16.01	17.40	19.14	20.88	52.20	
3.40	3.08	12.32	13.24	14.17	15.40	16.94	18.48	46.20	
3.60	2.76	11.04	11.87	12.70	13.80	15.18	16.56	41.40	
3.80	2.50	10.00	10.75	11.50	12.50	13.75	15.00	37.50	
4.00	2.29	9.16	9.85	10.53	11.45	12.60	13.74	34.35	
4.20	2.11	8.44	9.07	9.71	10.55	11.61	12.66	31.65	
4.40	1.95	7.80	8.39	8.97	9.75	10.73	11.70	29.25	
4.60	1.82	7.28	7.83	8.37	9.10	10.01	10.92	27.30	
4.80	1.70	6.80	7.31	7.82	8.50	9.35	10.20	25.50	
5.00	1.60	6.40	6.88	7.36	8.00	8.80	9.60	24.00	
5.20	1.51	6.04	6.49	6.95	7.55	8.31	9.06	22.65	
5.40	1.43	5.72	6.15	6.58	7.15	7.87	8.58	21.45	
5.60	1.36	5.44	5.85	6.26	6.80	7.48	8.16	20.40	
5.80	1.29	5.16	5.55	5.93	6.45	7.10	7.74	19.35	
6.00	1.23	4.92	5.29	5.66	6.15	6.77	7.38	18.45	
6.20	1.18	4.72	5.07	5.43	5.90	6.49	7.08	17.70	
6.40	1.13	4.52	4.86	5.20	5.65	6.22	6.78	16.95	
6.60	1.08	4.32	4.64	4.97	5.40	5.94	6.48	16.20	
6.80	1.04	4.16	4.47	4.78	5.20	5.72	6.24	15.60	
7.00	1.00	4.00	4.30	4.60	5.00	5.50	6.00	15.00	
8.00	1.00	4.00	4.30	4.60	5.00	5.50	6.00	15.00	

The information in this document is subject to change without further notice.

JIANGSU SFERE ELECTRIC CO., LTD.

Add: No.1 Dongding Road, Jiangyin, Jiangsu, China.

P.C: 214437

Tel: +86-510-86199063 +86-510-86199069 +86-510-86199073

Email: export@sfere-elec.com

Website: www.sfere-elecnova.com